



มาตรฐานผลิตภัณฑ์อุตสาหกรรม

THAI INDUSTRIAL STANDARD

มอก. 1441 เล่ม 4–2549

CISPR 16– 1– 4(2004–05)

ข้อกำหนดสำหรับอุปกรณ์และวิธีการวัดสัญญาณ รบกวนวิทยุและภูมิคุ้มกัน

เล่ม 1–4 อุปกรณ์วัดสัญญาณรบกวนวิทยุและภูมิคุ้มกัน –
บริภัณฑ์ช่วย – สัญญาณรบกวนที่แผ่ออก

SPECIFICATION FOR RADIO DISTURBANCE AND IMMUNITY
MEASURING APPARATUS AND METHODS–
PART 1–4 : RADIO DISTURBANCE AND IMMUNITY MEASURING APPARATUS–
ANCILLARY EQUIPMENT–RADIATED DISTURBANCES

สำนักงานมาตรฐานผลิตภัณฑ์อุตสาหกรรม

กระทรวงอุตสาหกรรม

ICS 33.100

ISBN 974-1509-42-1

มาตรฐานผลิตภัณฑ์อุตสาหกรรม
ข้อกำหนดสำหรับอุปกรณ์และวิธีการวัดสัญญาณ
รบกวนวิทยุและภูมิคุ้มกัน

เล่ม 1-4 อุปกรณ์วัดสัญญาณรบกวนวิทยุและภูมิคุ้มกัน –
บริษัทช่วย – สัญญาณรบกวนที่แผ่ออก

มอก. 1441 เล่ม 4 – 2549

สำนักงานมาตรฐานผลิตภัณฑ์อุตสาหกรรม
กระทรวงอุตสาหกรรม ถนนพระรามที่ 6 กรุงเทพฯ 10400
โทรศัพท์ 0 2202 3300

ประกาศในราชกิจจานุเบกษาฉบับประกาศและงานทั่วไปเล่ม 123 ตอนที่ 77ง
วันที่ 10 สิงหาคม พุทธศักราช 2549

บริษัทที่ไฟฟ้าและอิเล็กทรอนิกส์ตลอดจนบริษัทเทคโนโลยีสารสนเทศในขณะใช้งานจะต้องไม่ส่งสัญญาณรบกวนเข้าสู่ระบบไฟฟ้าหรือรบกวนการทำงานของบริษัทข้างเคียง รวมทั้งตัวบริษัทเองก็ต้องมีภูมิคุ้มกันในระดับเพียงพอที่จะทำงานในสภาวะแวดล้อมทางแม่เหล็กไฟฟ้าในระดับหนึ่งได้จึงกำหนดมาตรฐานผลิตภัณฑ์อุตสาหกรรม ข้อกำหนดสำหรับอุปกรณ์และวิธีการวัดสัญญาณรบกวนวิทยุและภูมิคุ้มกัน เล่ม 1-4 อุปกรณ์วัดสัญญาณรบกวนวิทยุและภูมิคุ้มกัน - บริษัทช่วย - สัญญาณรบกวนที่แผ่ออก ขึ้น

มาตรฐานผลิตภัณฑ์อุตสาหกรรมนี้กำหนดขึ้นโดยรับ CISPR 16-1-4(2004-05) Specification for radio disturbance and immunity measuring apparatus and methods - Part 1-4 : Radio disturbance and immunity measuring apparatus - Ancillary equipment - Radiated disturbances มาใช้ในระดับเหมือนกันทุกประการ(identical) โดยใช้ CISPR ฉบับภาษาอังกฤษเป็นหลัก

มาตรฐานผลิตภัณฑ์อุตสาหกรรมนี้กำหนดขึ้นเพื่อใช้ในการอ้างอิง และเพื่อให้ทันกับความต้องการของผู้ใช้มาตรฐานซึ่งจะได้แปลเป็นภาษาไทยในโอกาสอันสมควรต่อไป หากมีข้อสงสัยโปรดติดต่อสอบถามสำนักงานมาตรฐานผลิตภัณฑ์อุตสาหกรรม

คณะกรรมการมาตรฐานผลิตภัณฑ์อุตสาหกรรมได้พิจารณามาตรฐานนี้แล้ว เห็นสมควรเสนอรัฐมนตรีประกาศตาม มาตรา 15 แห่งพระราชบัญญัติมาตรฐานผลิตภัณฑ์อุตสาหกรรม พ.ศ. 2511



ประกาศกระทรวงอุตสาหกรรม

ฉบับที่ 3489 (พ.ศ. 2549)

ออกตามความในพระราชบัญญัติมาตรฐานผลิตภัณฑ์อุตสาหกรรม

พ.ศ. 2511

เรื่อง กำหนดมาตรฐานผลิตภัณฑ์อุตสาหกรรม

ข้อกำหนดสำหรับอุปกรณ์และวิธีการวัดสัญญาณรบกวนวิทยุและภูมิคุ้มกัน

เล่ม 1-4 อุปกรณ์วัดสัญญาณรบกวนวิทยุและภูมิคุ้มกัน -

บริษัทช่วย - สัญญาณรบกวนที่แผ่ออก

อาศัยอำนาจตามความในมาตรา 15 แห่งพระราชบัญญัติมาตรฐานผลิตภัณฑ์อุตสาหกรรม พ.ศ. 2511 รัฐมนตรีว่าการกระทรวงอุตสาหกรรมออกประกาศกำหนดมาตรฐานผลิตภัณฑ์อุตสาหกรรม ข้อกำหนดสำหรับ อุปกรณ์และวิธีการวัดสัญญาณรบกวนวิทยุและภูมิคุ้มกัน เล่ม 1-4 อุปกรณ์วัดสัญญาณรบกวนวิทยุและภูมิคุ้มกัน - บริษัทช่วย - สัญญาณรบกวนที่แผ่ออก มาตรฐานเลขที่ มอก. 1441 เล่ม 4-2549 ไว้ ดังมีรายละเอียดต่อท้าย ประกาศนี้

ประกาศ ณ วันที่ 26 เมษายน พ.ศ. 2549

สุริยะ จึงรุ่งเรืองกิจ

รัฐมนตรีว่าการกระทรวงอุตสาหกรรม

มาตรฐานผลิตภัณฑ์อุตสาหกรรม
ข้อกำหนดสำหรับอุปกรณ์และวิธีการวัดสัญญาณรบกวนวิทยุและภูมิคุ้มกัน
เล่ม 1-4 อุปกรณ์วัดสัญญาณรบกวนวิทยุและภูมิคุ้มกัน -
บริษัทช่วย - สัญญาณรบกวนที่แผ่ออก

มาตรฐานผลิตภัณฑ์อุตสาหกรรมนี้กำหนดขึ้นโดยรับ CISPR 16-1-4(2004-05) Specification for radio disturbance and immunity measuring apparatus and methods - Part 1-4: Radio disturbance and immunity measuring apparatus - Ancillary equipment- Radiated disturbances มาใช้ในระดับเหมือนกันทุกประการ (identical) โดยใช้ CISPR ฉบับภาษาอังกฤษเป็นหลัก

มาตรฐานผลิตภัณฑ์อุตสาหกรรมนี้ได้รับการระบุให้เป็นมาตรฐานพื้นฐาน ซึ่งกำหนดลักษณะเฉพาะและสมรรถนะของบริษัทสำหรับวัดสัญญาณรบกวนที่แผ่ออก ในพิสัยความถี่ 9 กิโลเฮิร์ตซ์ ถึง 18 จิกะเฮิร์ตซ์

ได้รวมข้อกำหนดสำหรับเครื่องสำเร็จช่วยไว้ในมาตรฐานนี้ด้วย ซึ่งได้แก่ข้อกำหนดของสายอากาศและสถานที่ทดสอบ เซลล์ TEM และห้องสะท้อน

คุณลักษณะที่ต้องการตามมาตรฐานนี้ต้องเป็นไปตามที่กำหนดที่ทุกความถี่และทุกระดับของสัญญาณรบกวนที่แผ่ออก ภายในพิสัยแสดงค่าของบริษัทวัด

วิธีการวัดครอบคลุมโดยเล่ม 2-3 และสารสนเทศเพิ่มเติมเกี่ยวกับสัญญาณรบกวนวิทยุให้ไว้ในเล่ม 3 ความไม่แน่นอน สถิติ และการทำแบบขีดจำกัด ครอบคลุมโดยเล่ม 4

รายละเอียดให้เป็นไปตาม CISPR 16-1-4(2004-05)

CONTENTS

FOREWORD	3
INTRODUCTION	5
TABLE RECAPITULATING CROSS REFERENCES	6
1 Scope	7
2 Normative references	7
3 Definitions	8
4 Antennas for measurement of radiated radio disturbance	10
5 Test sites for measurement of radio disturbance field strength for the frequency range of 30 MHz to 1 000 MHz	18
6 Reverberating chamber for total radiated power measurement	79
7 TEM cells for immunity to radiated disturbance measurement	42
8 Test sites for measurement of radio disturbance field strength for the frequency range 1 GHz to 18 GHz	42
Annex A (normative) Parameters of broadband antennas	44
Annex B (normative) Monopole (1 m rod antenna) performance equations and characterization of the associated antenna matching network	48
Annex C (normative) Loop antenna system for magnetic field induced current measurements in the frequency range of 9 kHz to 30 MHz	53
Annex D (informative) Construction details for open area test sites in the frequency range of 30 MHz to 1 000 MHz (clause 5)	62
Annex E (normative) Validation procedure of the open area test site for the frequency range of 30 MHz to 1 000 MHz (clause 5)	65
Annex F (informative) Basis for 4 dB site acceptability criterion (clause 5)	73

INTERNATIONAL ELECTROTECHNICAL COMMISSION
INTERNATIONAL SPECIAL COMMITTEE ON RADIO INTERFERENCE

**SPECIFICATION FOR RADIO DISTURBANCE AND IMMUNITY
MEASURING APPARATUS AND METHODS –**

**Part 1-4: Radio disturbance and immunity measuring apparatus –
Ancillary equipment – Radiated disturbances**

FOREWORD

- 1) The International Electrotechnical Commission (IEC) is a worldwide organization for standardization comprising all national electrotechnical committees (IEC National Committees). The object of IEC is to promote international co-operation on all questions concerning standardization in the electrical and electronic fields. To this end and in addition to other activities, IEC publishes International Standards, Technical Specifications, Technical Reports, Publicly Available Specifications (PAS) and Guides (hereafter referred to as "IEC Publication(s)"). Their preparation is entrusted to technical committees; any IEC National Committee interested in the subject dealt with may participate in this preparatory work. International, governmental and non-governmental organizations liaising with the IEC also participate in this preparation. IEC collaborates closely with the International Organization for Standardization (ISO) in accordance with conditions determined by agreement between the two organizations.
- 2) The formal decisions or agreements of IEC on technical matters express, as nearly as possible, an international consensus of opinion on the relevant subjects since each technical committee has representation from all interested IEC National Committees.
- 3) IEC Publications have the form of recommendations for international use and are accepted by IEC National Committees in that sense. While all reasonable efforts are made to ensure that the technical content of IEC Publications is accurate, IEC cannot be held responsible for the way in which they are used or for any misinterpretation by any end user.
- 4) In order to promote international uniformity, IEC National Committees undertake to apply IEC Publications transparently to the maximum extent possible in their national and regional publications. Any divergence between any IEC Publication and the corresponding national or regional publication shall be clearly indicated in the latter.
- 5) IEC provides no marking procedure to indicate its approval and cannot be rendered responsible for any equipment declared to be in conformity with an IEC Publication.
- 6) All users should ensure that they have the latest edition of this publication.
- 7) No liability shall attach to IEC or its directors, employees, servants or agents including individual experts and members of its technical committees and IEC National Committees for any personal injury, property damage or other damage of any nature whatsoever, whether direct or indirect, or for costs (including legal fees) and expenses arising out of the publication, use of, or reliance upon, this IEC Publication or any other IEC Publications.
- 8) Attention is drawn to the Normative references cited in this publication. Use of the referenced publications is indispensable for the correct application of this publication.
- 9) Attention is drawn to the possibility that some of the elements of this IEC Publication may be the subject of patent rights. IEC shall not be held responsible for identifying any or all such patent rights.

International Standard CISPR 16-1-4 has been prepared by CISPR subcommittee A: Radio interference measurements and statistical methods.

This consolidated version of CISPR 16-1-4 is based on the first edition (2003) and its amendment 1 (2004) [documents CISPR/A/499/FDIS and CISPR/A/514/RVD].

It bears the edition number 1.1.

A vertical line in the margin shows where the base publication has been modified by amendment 1.

This publication has been drafted in accordance with the ISO/IEC Directives, Part 2.

The committee has decided that the contents of the base publication and its amendments will remain unchanged until 2005. At this date, the publication will be

- reconfirmed;
- withdrawn;
- replaced by a revised edition, or
- amended.

The contents of the corrigendum of February 2005 have been included in this copy.

INTRODUCTION

CISPR 16-1, CISPR 16-2, CISPR 16-3 and CISPR 16-4 have been reorganised into 14 parts, to accommodate growth and easier maintenance. The new parts have also been renumbered. See the list given below.

Old CISPR 16 publications		New CISPR 16 publications	
CISPR 16-1	Radio disturbance and immunity measuring apparatus	→	CISPR 16-1-1 Measuring apparatus
		→	CISPR 16-1-2 Ancillary equipment – Conducted disturbances
		→	CISPR 16-1-3 Ancillary equipment – Disturbance power
		→	CISPR 16-1-4 Ancillary equipment – Radiated disturbances
		→	CISPR 16-1-5 Antenna calibration test sites for 30 MHz to 1 000 MHz
CISPR 16-2	Methods of measurement of disturbances and immunity	→	CISPR 16-2-1 Conducted disturbance measurements
		→	CISPR 16-2-2 Measurement of disturbance power
		→	CISPR 16-2-3 Radiated disturbance measurements
		→	CISPR 16-2-4 Immunity measurements
CISPR 16-3	Reports and recommendations of CISPR	→	CISPR 16-3 CISPR technical reports
		→	CISPR 16-4-1 Uncertainties in standardised EMC tests
		→	CISPR 16-4-2 Measurement instrumentation uncertainty
		→	CISPR 16-4-3 Statistical considerations in the determination of EMC compliance of mass-produced products
CISPR 16-4	Uncertainty in EMC measurements	→	CISPR 16-4-4 Statistics of complaints and a model for the calculation of limits

More specific information on the relation between the 'old' CISPR 16-1 and the present 'new' CISPR 16-1-4 is given in the table after this introduction (TABLE RECAPITULATING CROSS REFERENCES).

Measurement instrumentation specifications are given in five new parts of CISPR 16-1, while the methods of measurement are covered now in four new parts of CISPR 16-2. Various reports with further information and background on CISPR and radio disturbances in general are given in CISPR 16-3. CISPR 16-4 contains information related to uncertainties, statistics and limit modelling.

CISPR 16-1 consists of the following parts, under the general title *Specification for radio disturbance and immunity measuring apparatus and methods – Radio disturbance and immunity measuring apparatus*:

- Part 1-1: Measuring apparatus,
- Part 1-2: Ancillary equipment – Conducted disturbances,
- Part 1-3: Ancillary equipment – Disturbance power,
- Part 1-4: Ancillary equipment – Radiated disturbances,
- Part 1-5: Antenna calibration test sites for 30 MHz to 1 000 MHz.

TABLE RECAPITULATING CROSS REFERENCES

Second edition of CISPR 16-1 Clauses, subclauses	First edition of CISPR 16-1-4 Clauses, subclauses
1	1
2	2
3	3
5.5	4
5.6	5
5.7	6
5.9	7
5.12	8
Annexes	Annexes
O	A
X	B
P	C
K	D
G	E
L	F
Figures	Figures
13, ..., 17	1, ..., 5
51	6
18,19	7,8
43	B.1
P.1, ..., P.11	C.1, ..., C.11
Tables	Tables
16,17	1,2

SPECIFICATION FOR RADIO DISTURBANCE AND IMMUNITY MEASURING APPARATUS AND METHODS –

Part 1-4: Radio disturbance and immunity measuring apparatus – Ancillary equipment – Radiated disturbances

1 Scope

This part of CISPR 16 is designated a basic standard, which specifies the characteristics and performance of equipment for the measurement of radiated disturbances in the frequency range 9 kHz to 18 GHz.

Specifications for ancillary apparatus are included for: antennas and test sites, TEM cells, and reverberating chambers.

The requirements of this publication shall be complied with at all frequencies and for all levels of radiated disturbances within the CISPR indicating range of the measuring equipment.

Methods of measurement are covered in Part 2-3, and further information on radio disturbance is given in Part 3 of CISPR 16. Uncertainties, statistics and limit modelling are covered in Part 4 of CISPR 16.

2 Normative references

The following referenced documents are indispensable for the application of this document. For dated references, only the edition cited applies. For undated references, the latest edition of the referenced document (including any amendments) applies.

CISPR 14-1:2000, *Electromagnetic compatibility – Requirements for household appliances, electric tools and similar apparatus – Part 1: Emission*

CISPR 16-1-1:2003, *Specification for radio disturbance and immunity measuring apparatus and methods – Part 1-1: Radio disturbance and immunity measuring apparatus - Measuring apparatus*

CISPR 16-1-5:2003, *Specification for radio disturbance and immunity measuring apparatus and methods – Part 1-5: Radio disturbance and immunity measuring apparatus – Antenna calibration and site validation*

CISPR 16-2-1:2003, *Specification for radio disturbance and immunity measuring apparatus and methods – Part 2-1: Methods of measurement of immunity and disturbance – Conducted disturbance measurements*

CISPR 16-2-3:2003, *Specification for radio disturbance and immunity measuring apparatus and methods – Part 2-3: Methods of measurement of immunity and disturbance – Radiated disturbance measurements*

CISPR 16-3:2003, *Specification for radio disturbance and Immunity measuring apparatus and methods – Part 3: CISPR technical reports*

CISPR 16-4-1:2003, *Specification for radio disturbance and immunity measuring apparatus and methods – Part 4-1: Uncertainties, statistics and limit modelling – Uncertainties in standardized EMC tests*

CISPR 16-4-2:2003, *Specification for radio disturbance and immunity measuring apparatus and methods – Part 4-2: Uncertainties, statistics and limit modelling – Measurement instrumentation uncertainties*

IEC 60050(161):1990, *International Electrotechnical Vocabulary (IEV) – Chapter 161: Electromagnetic compatibility*

International Vocabulary of Basic and General Terms in Metrology, International Organization for Standardization, Geneva, 2nd edition, 1993

3 Definitions

For the purpose of this part of CISPR 16, the following definitions apply. Also see IEC 60050 (161).

3.1

bandwidth (B_n)

the width of the overall selectivity curve of the receiver between two points at a stated attenuation, below the midband response. The bandwidth is represented by the symbol B_n , where n is the stated attenuation in decibels

3.2

CISPR indicating range

it is the range specified by the manufacturer which gives the maximum and the minimum meter indications within which the receiver meets the requirements of this part of CISPR 16

3.3

calibration test site (CALTS)

open area test site with metallic ground plane and tightly specified site attenuation performance in horizontal and vertical electric field polarization.

A CALTS is used for determining the free-space antenna factor of an antenna.

Site attenuation measurements of a CALTS are used for comparison to corresponding site attenuation measurements of a compliance test site, in order to evaluate the performance of the compliance test site

3.4

compliance test site (COMTS)

environment which assures valid, repeatable measurement results of disturbance field strength from equipment under test for comparison to a compliance limit

3.5**antenna**

that part of a transmitting or receiving system that is designed to radiate or to receive electromagnetic waves in a specified way

NOTE 1 In the context of this standard, the balun is a part of the antenna.

NOTE 2 See also the term "wire antenna".

3.6**balun**

passive electrical network for the transformation from a balanced to an unbalanced transmission line or device or vice versa

3.7**free-space-resonant dipole**

wire antenna consisting of two straight colinear conductors of equal length, placed end to end, separated by a small gap, with each conductor approximately a quarter-wavelength long such that at the specified frequency the input impedance of the wire antenna measured across the gap is pure real when the dipole is located in the free space

NOTE 1 In the context of this standard, this wire antenna connected to the balun is also called the "test antenna".

NOTE 2 This wire antenna is also referred to as "tuned dipole".

3.8**site attenuation**

site attenuation between two specified positions on a test site is the insertion loss determined by a two-port measurement, when a direct electrical connection between the generator output and receiver input is replaced by transmitting and receiving antennae placed at the specified positions

3.9**test antenna**

combination of the free-space-resonant dipole and the specified balun

NOTE For the purpose of this standard only.

3.10**wire antenna**

a specified structure consisting of one or more metallic wires or rods for radiating or receiving electromagnetic waves

NOTE A wire antenna does not contain a balun.

3.11**fully anechoic room****FAR**

shielded enclosure, the internal surfaces of which are lined with radio-frequency absorbing material (i.e. RF absorber), which absorbs electromagnetic energy in the frequency range of interest

3.12**quasi-free space test-site**

test-site for which the site attenuation measured with vertically polarized tuned dipoles deviates by no more than ± 1 dB from the calculated free-space attenuation at any frequency

3.13

test volume

volume in the FAR in which the EUT is positioned

NOTE In this volume the quasi-free space condition is met and this volume is typically 0,5 m or more from the absorbing material of the FAR.

4 Antennas for measurement of radiated radio disturbance

The antenna and the circuits inserted between it and the measuring receiver shall not appreciably affect the overall characteristics of the measuring receiver. When the antenna is connected to the measuring receiver, the measuring system shall comply with the bandwidth requirements of CISPR 16-1-1 appropriate to the frequency band concerned.

The antenna shall be substantially plane polarized. It shall be orientable so that all polarizations of incident radiation can be measured. The height of the centre of the antenna above ground may have to be adjustable according to a specific test procedure.

For additional information about the parameters of broadband antennas see annex A.

4.1 Accuracy of field-strength measurements

The accuracy of field-strength measurement of a uniform field of a sine-wave shall be better than ± 3 dB when an antenna meeting the requirements of this subclause is used with a measuring receiver meeting the requirements of CISPR 16-1-1.

NOTE This requirement does not include the effect due to a test site.

4.2 Frequency range 9 kHz to 150 kHz

Experience has shown that, in this frequency range, it is the magnetic field component that is primarily responsible for observed instances of interference.

4.2.1 Magnetic antenna

For measurement of the magnetic component of the radiation, either an electrically-screened loop antenna of dimension such that the antenna can be completely enclosed by a square having sides of 60 cm in length, or an appropriate ferrite-rod antenna, may be used.

The unit of the magnetic field strength is $\mu\text{A/m}$ or, in logarithmic units, $20 \log(\mu\text{A/m}) = \text{dB}(\mu\text{A/m})$. The associated emission limit shall be expressed in the same units.

NOTE Direct measurements can be made of the strength of the magnetic component, in $\text{dB}(\mu\text{A/m})$ or $\mu\text{A/m}$ of a radiated field under all conditions, that is, both in the near field and in the far field. However, many field strength measuring receivers are calibrated in terms of the equivalent plane wave electric field strength in $\text{dB}(\mu\text{V/m})$, i.e. assuming that the ratio of the E and H components is 120π or 377Ω . This assumption is justified under far-field conditions at distances from the source exceeding one sixth of a wavelength ($\lambda/2\pi$), and in such cases the correct value for the H component can be obtained by dividing the E value indicated on the receiver by 377, or by subtracting 51,5 dB from the E level in $\text{dB}(\mu\text{V/m})$ to give the H level in $\text{dB}(\mu\text{A/m})$.

It should be clearly understood that the above fixed E and H ratio applies only under far-field conditions.

To obtain the reading of H ($\mu\text{A/m}$), the reading E ($\mu\text{V/m}$) is divided by 377Ω :

$$H (\mu\text{A/m}) = E (\mu\text{V/m}) / 377 \Omega \quad (1)$$

To obtain the reading of H dB($\mu\text{A/m}$), $51,5 \text{ dB}(\Omega)$ is subtracted from the reading E dB($\mu\text{V/m}$):

$$H \text{ dB}(\mu\text{A/m}) = E \text{ dB}(\mu\text{V/m}) - 51,5 \text{ dB}(\Omega) \quad (2)$$

The impedance $Z = 377 \Omega$, with $20 \log Z = 51,5 \text{ dB}(\Omega)$, used in the above conversions is a constant originating from the calibration of field strength measuring equipment indicating the magnetic field in $\mu\text{V/m}$ (or dB($\mu\text{V/m}$)).

4.2.2 Balance of antenna

The balance of the antenna shall be such that, when the antenna is rotated in a uniform field, the level in the cross-polarization direction is at least 20 dB below that in the parallel polarization direction.

4.3 Frequency range 150 kHz to 30 MHz

4.3.1 Electric antenna

For the measurement of the electric component of the radiation, either a balanced or an unbalanced antenna may be used. If an unbalanced antenna is used, the measurement will refer only to the effect of the electric field on a vertical rod antenna. The type of antenna used shall be stated with the results of the measurements.

Information pertaining to calculating the performance characteristics of a 1 m length monopole (rod) antenna and the characterization of its matching network is specified in Annex B.

Where the distance between the source of radiation and the antenna is 10 m or less, the total length of the antenna shall be 1 m. For distances greater than 10 m the preferred antenna length is 1 m, but in no case shall it exceed 10 % of the distance.

The unit of electric field strength shall be $\mu\text{V/m}$ or, in logarithmic units, $20 \log(\mu\text{V/m}) = \text{dB}(\mu\text{V/m})$. The associated emission limit shall be expressed in the same units.

4.3.2 Magnetic antenna

For the measurement of the magnetic component of the radiation, an electrically-screened loop antenna, as described in 4.2.1 shall be used.

Tuned electrically balanced loop antennas may be used to make measurements at lower field strengths than untuned electrically-screened loop antennas.

4.3.3 Balance of antenna

If a balanced electric or a magnetic antenna is used, it shall comply with the requirement of 4.2.2.

4.4 Frequency range 30 MHz to 300 MHz

4.4.1 Electric antenna

The reference antenna shall be a balanced dipole.

4.4.1.1 Balanced dipole

For frequencies 80 MHz or above, the antenna shall be resonant in length, and for frequencies below 80 MHz it shall have a length equal to the 80 MHz resonant length and shall be tuned and matched to the feeder by a suitable transforming device. Connection to the input of the measuring apparatus shall be made through a symmetric-asymmetric transformer arrangement.

4.4.1.2 Shortened dipole

A dipole shorter than a half wavelength may be used provided:

- a) the total length is greater than 1/10 of a wavelength at the frequency of measurement;
- b) it is connected to a cable sufficiently well matched at the receiver end to ensure a voltage standing wave ratio (v.s.w.r.) on the cable of less than 2.0 to 1. The calibration shall take account of the v.s.w.r.;
- c) it has a polarization discrimination equivalent to that of a tuned dipole (see 4.4.2). To obtain this, a balun may be helpful;
- d) for determination of the measured field strength, a calibration curve (antenna factor) is determined and used in the measuring distance (i.e., at a distance of at least three times the length of the dipole);

NOTE The antenna factors thus obtained should make it possible to fulfil the requirement of measuring uniform sine-wave fields with an accuracy not worse than ± 3 dB. Examples of calibration curves are given in figure 1 which shows the theoretical relation between field strength and receiver input voltage for a receiver of input impedance of 50Ω , and for various l/d ratios. On these figures, the balun is considered as an ideal 1:1 transformer. It should be noted, however, that these curves do not account for the losses of the balun, the cable and any mismatch between the cable and the receiver.

- e) in spite of the sensitivity loss of the field-strength meter due to a high antenna factor attributed to the shortened length of the dipole, the measuring limit of the field-strength meter (determined for example by the noise of the receiver and the transmission factor of the dipole) shall remain at least 10 dB below the level of the measured signal.

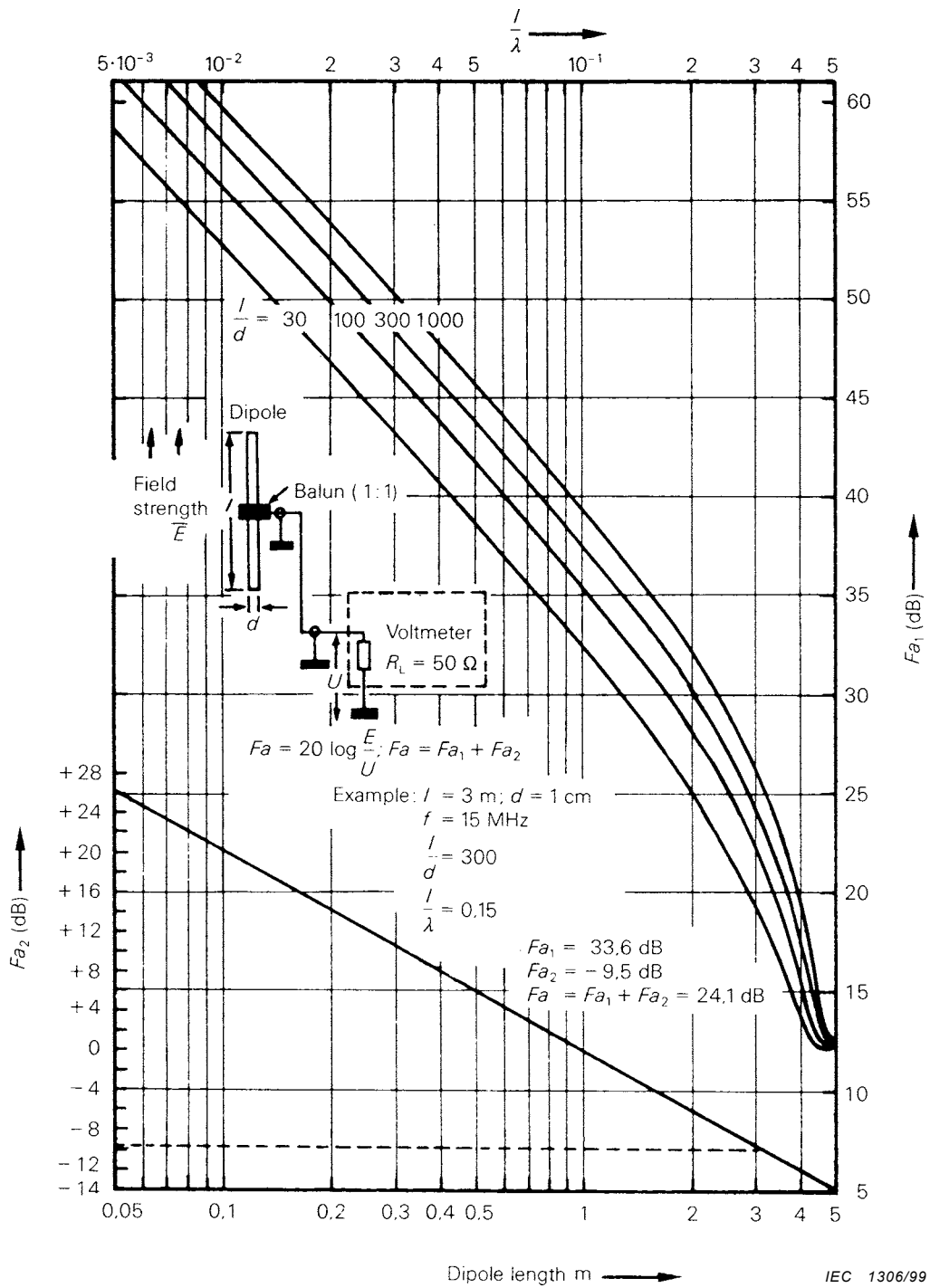

Figure 1 – Short dipole antenna factors for $R_L = 50 \Omega$

4.4.1.3 Broadband antenna

A broadband antenna may be used, provided that it meets the requirements given in 4.5.2 for a complex antenna.

4.4.2 Balance of antenna

4.4.2.1 Introduction

In radiated emission measurements, common-mode (CM) currents may be present on the cable attached to the receiving antenna (the antenna cable). In turn, these CM currents create EM fields which may be picked up by the receiving antenna. Consequently, the radiated emission measuring results may be influenced.

The major contributions to the antenna cable CM currents stem from

- a) the electric field generated by the EUT, if that field has a component parallel to the antenna cable, and
- b) the conversion of the differential mode (DM) antenna signal (the desired signal) into a CM signal by the imperfection of the balun of the receiving antenna.

This subclause considers the balun contribution. Contribution a) is under consideration (see last sentence of NOTE 1 of 4.4.2.2).

In general, log-periodic dipole array antennas do not exhibit significant DM/CM conversion and the following check applies to dipoles, biconical antennas and bicone/log hybrid antennas.

4.4.2.2 Balun DM/CM conversion check

The following method describes the measurement of two voltages, U_1 and U_2 , in the frequency range for which the receiving antenna is to be used. The ratio of these voltages, both expressed in identical units (e.g., dB μ V), is a measure for the DM/CM conversion.

- 1) Set the receiving antenna under test vertically polarized with its centre at a height of 1,5 m above the ground plane. Lay the cable horizontally for $1,5 \text{ m} \pm 0,1 \text{ m}$ behind the rear active element of the antenna and then drop it vertically by a height of at least 1.5 m to the ground plane.
- 2) Place a second (transmitting) antenna vertically polarized at a horizontal distance of 10 m from the centre of the antenna under test with its tip 0,10 m from the ground plane. If the range of the site used for emission testing is 3 m, do this check using a distance of 3 m (if the conversion check has already been made at 10 m distance and shows a change of less than $\pm 0,5 \text{ dB}$, it is not necessary to take a separate measurement at 3 m). The specification of the transmitting antenna shall include the frequency range of the antenna under test.
- 3) Connect the transmitting antenna to a signal source, for example, a tracking generator, set the level of that generator in such a way that, over the frequency range of interest, the signal-to-ambient noise at the receiver is larger than 10 dB.
- 4) Record the voltage U_1 at the receiver over the frequency range of interest.
- 5) Invert the receiving antenna (rotate that antenna through 180°) without changing anything else in the set-up, in particular the receiving antenna cable, and without changing the setting of the signal source.
- 6) Record the voltage U_2 at the receiver over the frequency range.

7) The DM/CM conversion is sufficiently low if $|20 \log (U_1/U_2)| < 1$ dB.

NOTE 1 If the DM/CM conversion criterion is not met, ferrite rings around the antenna cable may reduce the DM/CM conversion. The addition of ferrites on the antenna cable may also be used to verify whether contribution a) has a non-negligible effect. Repeat the test with four ferrites spaced approximately 20 cm apart. If the criterion is met by using these rings, they shall be present in the actual emission measurement. Likewise, the interaction with the cable can be reduced by extending the cable several metres behind the antenna before dropping to ground.

NOTE 2 If the receiving antenna is to be used in a fully anechoic chamber, the DM/CM check may be performed in that room with the receiving antenna at its usual location and the transmitting antenna in the centre of the test volume of that room. The room must comply with the ± 4 dB criterion

NOTE 3 The measuring site of which the ground plane forms a part, or the fully anechoic room, should comply with their respective NSA requirements.

NOTE 4 The horizontal distance of 1,5 m over which the antenna cable runs horizontally behind the centre of the antenna shall be kept as a minimum during actual vertically polarized radiated emissions measurements.

NOTE 5 It is not necessary to define a test set-up strictly because this effect is in large part due to the interaction of the antenna and the part of input cable that lies parallel to the antenna elements. There is a much smaller effect which is dependent on the uniformity of the field incident on the antenna in normal EMC set-ups on an OATS or in a fully anechoic room.

NOTE 6 For baluns which have the receive cable connector mounted on the side (90° to the antenna boom), a right angle connector should be used to reduce the movement of the cable.

4.4.3 Cross-polar performance of antenna

When an antenna is placed in a plane-polarized electromagnetic field, the terminal voltage when the antenna and field are cross-polarized shall be at least 20 dB below the terminal voltage when they are co-polarized. It is intended that this test apply to log-periodic dipole array (LPDA) antennas for which the two halves of each dipole are in echelon. The majority of testing with such antennas is above 200 MHz, but the requirement applies below 200 MHz. This test is not intended for in-line dipole and biconical antennas because a cross-polar rejection greater than 20 dB is intrinsic to their symmetrical design. Such antennas and horn antennas must have a cross-polar rejection greater than 20 dB and a type test by the manufacturer should confirm this.

In order to achieve quasi-free space conditions, a high-quality anechoic chamber or towers of sufficient height above ground on an outdoor range can be used. To minimize ground reflections set the antennas vertically polarized. A plane wave shall be set up at the antenna under test. The separation between the centre of the antenna under test and the source antenna shall be greater than one wavelength.

NOTE A good-quality site is needed to set up a plane wave at the antenna under test. The cross-polar discrimination afforded by the plane wave can be proven by transmitting between a pair of horn antennas or open-ended waveguides and checking that the combination of site error and inherent cross-polar performance of one horn antenna yields a suppression of the horizontal component by more than 30 dB. If the site errors are very low and if the horn antennas have identical performance, the cross-polar performance of one horn is approximately 6 dB lower than the combined cross-polar coupling of the pair of horns.

An interfering signal 20 dB lower in level than the desired signal gives a maximum error on the desired signal of $\pm 0,9$ dB. The maximum error occurs when the cross-polar signal is in phase with the co-polar signal. If the cross-polar response of the LPDA is worse than 20 dB, the operator must calculate the uncertainty and declare it with the result. For example a cross-polar level of 14 dB implies a maximum uncertainty of +1,6 dB to -1,9 dB. Take the larger value and assume a U-shaped distribution when calculating the standard uncertainty.

To add a signal of 0 dB to another of -14 dB, first convert to relative voltages by dividing by 20 and taking the anti-log. Then add the smaller signal to the unity signal. Take the log and multiply by 20. The result is the positive decibel error. Repeat, but subtracting the smaller signal from the unity signal to give the negative decibel error.

For the purpose of calculating the uncertainty of the result of a radiated emission, if the signal level measured in one polarization exceeds the signal measured in the orthogonal polarization by 6 dB or more, then an LPDA whose cross-polar discrimination is only 14 dB will have been deemed to have met the specification of 20 dB. If the difference between the VP and HP signal levels is less than 6 dB, additional uncertainty must be calculated if the sum of this difference and the cross-polarization is less than 20 dB.

4.5 Frequency range 300 MHz to 1 000 MHz

4.5.1 Electric antenna

If a dipole antenna is used, it shall meet the requirements of 4.4.1.1 and 4.4.2.

4.5.2 Complex antenna

Since, at the frequencies in the range 300 MHz to 1 000 MHz, the sensitivity of the simple dipole antenna is low, a more complex antenna may be used. Such antenna shall be as follows:

- a) The antenna shall be substantially plane polarized. This shall be checked in the same manner as for the balance of a simple dipole antenna.
- b) The main lobe of the radiation pattern of the antenna shall be such that the response in the direction of the direct ray and that in the direction of the ray reflected from the ground do not differ by more than 1 dB.

To ensure this condition, the total vertical angular aperture 2φ of the measuring antenna, within which the antenna gain is within 1 dB of its maximum, shall be such that:

- 1) if the measuring antenna is maintained in a horizontally direct position:

$$\varphi > \tan^{-1} [(h_1 + h_2)/d]$$

- 2) if the measuring antenna is tilted towards earth in the optimum position (so that direct and reflected rays are included within the aperture 2φ):

$$2\varphi > \tan^{-1} [(h_1 + h_2)/d] - \tan^{-1} [(h_1 - h_2)/d]$$

where

h_1 is the measuring antenna height;

h_2 is the height of the device under test;

d is the horizontal distance between the measuring antenna and the device under test.

The pattern of the antenna shall be checked in the horizontal plane while orienting it for vertical polarization. It shall be assumed that the pattern and, in particular, the angular aperture 2φ is the same when horizontally polarized as when measured with the vertical polarization.

It is essential that the variation of the effective distance of the antenna from the source and its gain with frequency be taken into account.

- c) The voltage standing-wave ratio of the antenna with the antenna feeder connected and measured from the receiver end shall not exceed 2,0 to 1.
- d) A calibration factor shall be given making it possible to fulfil the requirements of 4.1.

4.6 Frequency range 1 GHz to 18 GHz

Radiated emissions measurements above 1 GHz shall be made using calibrated, linearly polarized antennas. These include double-ridged guide horns, rectangular wave guide horns, pyramidal horns, optimum gain horns and standard gain horns. The "beam" or main lobe of

the pattern of any antenna used shall be large enough to encompass the EUT when located at the

measuring distance, or provisions shall be made for "scanning" the EUT to locate the direction or source of its radiated emissions. The width of the main lobe is defined as the 3 dB beamwidth of the antenna, and information enabling the determination of this parameter should be given in the antenna documentation. The aperture dimensions of these horn antennas shall be small enough so that the measurement distance R_m in metres is equal to or greater than the following minimum distance:

$$R_m \geq D^2/2\lambda$$

where

D is the largest dimension of the aperture in metres of the antenna;

λ is the free space wavelength in metres at the frequency of measurement.

In case of dispute, measurements made with a standard gain horn antenna or a similar precisely calibrated horn antenna shall take precedence.

NOTE Any calibrated, linearly polarized antenna, e.g. a log periodic dipole array, may be used to make these measurements. The gain of many antennas other than horn antennas in this frequency range may be inadequate if the antennas are used with spectrum analyzers or older radio noise meters. The tester shall assure that the overall measurement sensitivity is at least 6 dB below the applicable limit at the measurement distance in use, and that any means used to improve sensitivity, e.g. a preamplifier, does not cause distortion, spurious signals, or other overload problems. Since a log periodic dipole array has a much wider beamwidth than a horn antenna, reflections from the ground plane may cause significant error in measurements that are made with a log periodic dipole array.

4.7 Special antenna arrangements

4.7.1 Loop antenna system

In the frequency range 9 kHz to 30 MHz the interference capability of the magnetic field component of the radiation of a single (EUT) can be determined by using a special loop antenna system (LAS). In the LAS, this capability is measured in terms of the currents induced by the magnetic field in the loop antennas of the LAS. The LAS allows indoor measurements.

The LAS consists of three circular, mutually perpendicular large-loop antennas (LLAs), having a diameter of 2 m, supported by a non-metallic base. A full description of the LAS is given in annex C.

The EUT is positioned in the centre of the LAS. The maximum dimensions of the EUT are limited so that the distance between the EUT and an LLA is at least 0,20 m. Guidelines for the routing of signal cables are given in clause C.3, note 2 and figure C.6. Cables should be routed together and leave the loop volume in the same octant of the cell and no closer than 0,4 m to any of the LAS loops.

The three mutually perpendicular LLAs allow measurement of the interference capability of all polarizations of the radiated field with the prescribed accuracy, and without rotation of the EUT or changing the orientation of the LLAs.

Each of the three LLAs shall comply with the validation requirements given in clause C.5.

NOTE Circular LLAs having a diameter different from the standardized diameter of 2 m may be used, provided their diameter $D \leq 4$ m and the distance between the EUT and a LA is at least $0,10(D)$ m. Correction factors for non-standardized diameters are given in clause C.6.

5 Test sites for measurement of radio disturbance field strength for the frequency range of 30 MHz to 1 000 MHz

An environment is required which assures valid, repeatable measurement results of disturbance field strength from equipment. For equipment which can only be tested in its place of use, different provisions have to be utilized.

5.1 Open area test site

Disturbance field-strength measurements are normally performed at an open area test site. Open area test sites are areas characteristic of cleared level terrain. Such test sites shall be void of buildings, electric lines, fences, trees, etc. and free from underground cables, pipelines, etc., except as required to supply and operate the equipment under test (EUT). Refer to annex D for specific construction recommendations for open area test sites for electromagnetic field tests in the range of 30 MHz to 1 GHz. The site validation procedure for open area test sites is given in 5.6 with further details in annex E. Annex F contains the acceptability criterion.

5.2 Weather protection enclosure

Weather protection is desirable if the test site is used throughout the year. A weather protection structure could either protect the whole test site including EUT and field strength measuring antenna or the EUT only. The materials used shall be RF transparent in order to cause no undesirable reflections and attenuation of the emitted field from the EUT.

The structure shall be shaped to allow easy removal of snow, ice or water. For further details, see annex D.

5.3 Obstruction-free area

For open area test sites, an obstruction-free area surrounding the EUT and field-strength measuring antenna is required. The obstruction-free area should be free from significant scatterers of electromagnetic fields, and should be large enough so that scatterers outside the obstruction-free area will have little effect on the fields measured by the field-strength measuring antenna. To determine the adequacy of this area, site validation tests should be performed.

Since the magnitude of the field scattered from an object depends on many factors (size of the object, distance from the EUT, orientation with respect to the EUT, conductivity and permittivity of the object, frequency, etc.), it is impractical to specify a reasonable obstruction-free area which is necessary and sufficient for all applications. The size and shape of the obstruction-free area are dependent upon the measurement distance and whether or not the EUT will be rotated. If the site is equipped with a turntable, the recommended obstruction-free area is an ellipse with the receiving antenna and EUT at the two foci and having a major axis equal to twice the measurement distance and a minor axis equal to the product of the measurement distance and the square root of 3 (see figure 2).

For this ellipse, the path of the undesired ray reflected from any object on the perimeter is twice the length of the direct ray path between the foci. If a large EUT is installed on the turntable, the obstruction-free area must be expanded so that the obstruction clearance distances exist from the perimeter of the EUT.

If the site is not equipped with a turntable, that is, the EUT is stationary, the recommended obstruction-free area is a circular area such that the radial distance from the boundary of the EUT to the boundary of the area is equal to the measurement distance multiplied by 1,5 (see figure 3). In this case, the antenna is moved around the EUT at the separation distance.

The terrain within the obstruction-free area should be flat. Small slopes needed for adequate drainage are acceptable. The flatness of the metallic ground plane, if used, is discussed in clause D.2. Measuring apparatus and test personnel should be situated outside the obstruction free area.

5.4 Ambient radio frequency environment of a test site

The ambient radio frequency levels at a test site shall be sufficiently low compared to the levels of measurements to be performed. The quality of the site in this respect may be assessed in four categories, listed below in their order of merit:

- a) the ambient emissions are 6 dB or more below the measurement levels,
- b) some ambient emissions are within 6 dB of the measurement levels,
- c) some ambient emissions are above the measurement levels, but are either aperiodic (i.e., sufficiently long in time between transmissions to allow a measurement to be made) or continuous, but only on limited identifiable frequencies,
- d) the ambient levels are above the measurement levels over a large portion of the measurement frequency range and occurring continuously.

The selection of a test site should ensure that the accuracy of the measurement is maintained given the environment and the degree of engineering skill available.

NOTE For perfect results, an ambient level 20 dB below the emission level measured is recommended.

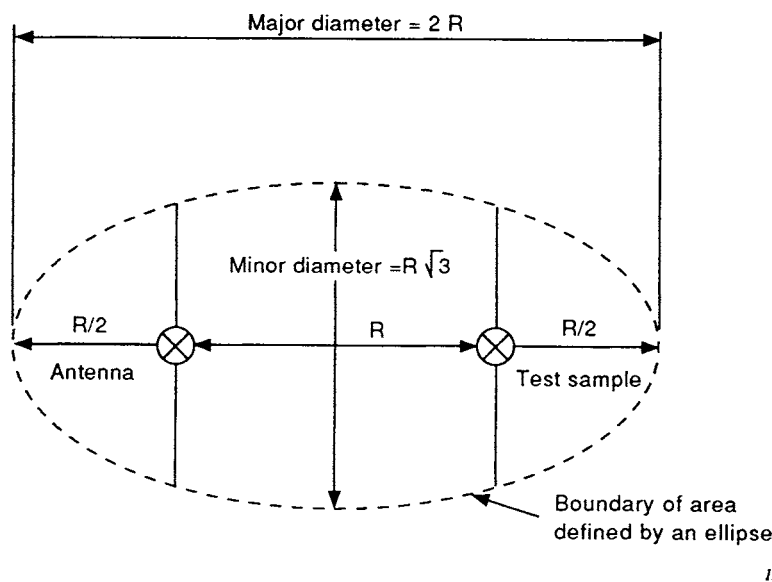

Figure 2 – Obstruction-free area of a test site with a turntable (see 5.3)

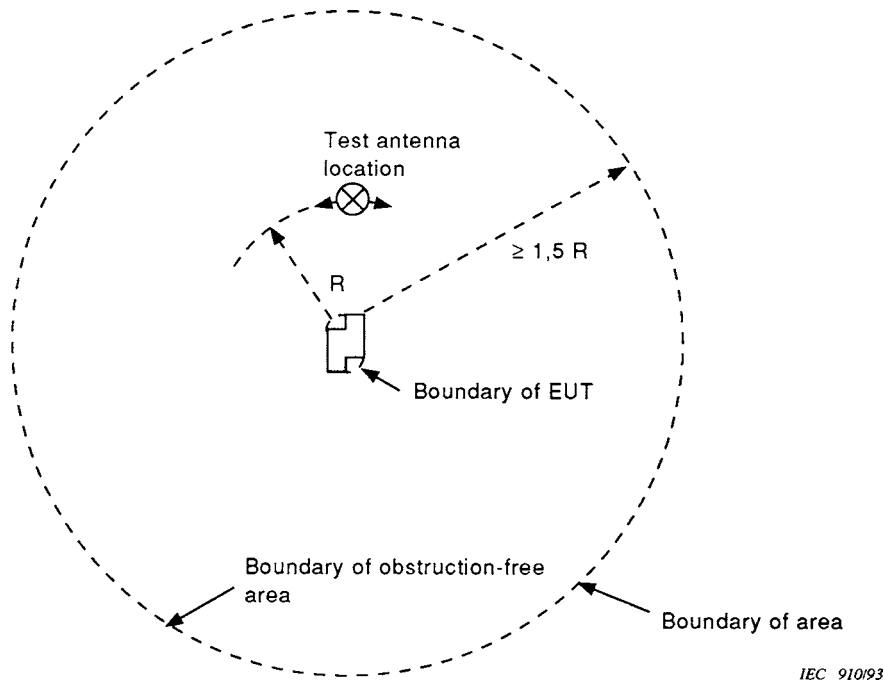

Figure 3 – Obstruction-free area with stationary EUT (see 5.3)

5.5 Ground plane

The ground plane may be composed of a wide range of material from earth to highly conductive, metallic material. The plane can be at earth level or elevated on a suitably sized platform or roof site. A metal ground plane is preferred, but for certain equipment and applications, it may not be recommended by certain product publications. Adequacy of the metal ground plane will be dependent on whether the test site meets the site validation requirements in 5.6. If no metallic material is used, caution is required to select a site that does not change its reflective characteristics with time, weather condition, or, due to buried metallic material such as pipes, conduits, and non-homogeneous soil. Such sites generally give different site attenuation characteristics compared to those with metallic surfaces.

5.6 Open area site validation procedure

The validation procedure and the requirements for the normalized site attenuation given here are used to qualify a test site when a metallic ground plane is specified. For other test sites, the validation procedure is of an informative nature, and will in general also identify possible site irregularities that should be investigated. The validation procedure is not applicable to absorber lined rooms. Such a procedure requires more detailed specifications and is under consideration.

The validation of an open area test site is performed with two antennas oriented horizontally and vertically with respect to the ground, as shown in figures 4 and 5, respectively. The open area site attenuation is obtained from the ratio of the source voltage (V_i) connected to a transmitting antenna and the received voltage (V_r) as measured on the receiving antenna terminals. The voltage measurements are performed in a 50Ω system. Suitable corrections for cable losses is required if V_r and V_i are not measured at the input and output of the transmit and receive antenna, respectively. This site attenuation ratio is then divided by the product of the antenna factors for the two antennas used. The resulting answer is the normalized site attenuation (NSA) and is expressed in dB. *The site is considered suitable when the measured*

vertical and horizontal NSA's are within ± 4 dB of the values given in tables E.1, E.2, and E.3, as appropriate. If the ± 4 dB criterion is exceeded, the test site must be investigated per clause E.4.

NOTE The basis for the 4 dB site acceptability criterion is given in annex F.

The deviation between a measured NSA value and the theoretical value shall not be used as a correction for a measured EUT field strength. This procedure shall be used only for validating a test site.

Table E.1 is used for broadband antennas such as biconical and log periodic arrays both horizontally and vertically aligned with respect to the ground plane. Table E.2 is for tuned half-wave dipoles aligned horizontally with respect to the ground plane. Table E.3 is for tuned half-wave dipoles vertically aligned with respect to the ground plane. Note that in table E.3, there are restrictions in the scan height h_2 . This takes into account the fact that the lowest tip of the receive dipole is kept 25 cm or more from the ground plane.

NOTE The reason for the different tables E.1 and E.2/E.3 is that different geometrical parameters are chosen for a broadband antenna and a tuned half-wave dipole, primarily because of practical restrictions needed for the latter.

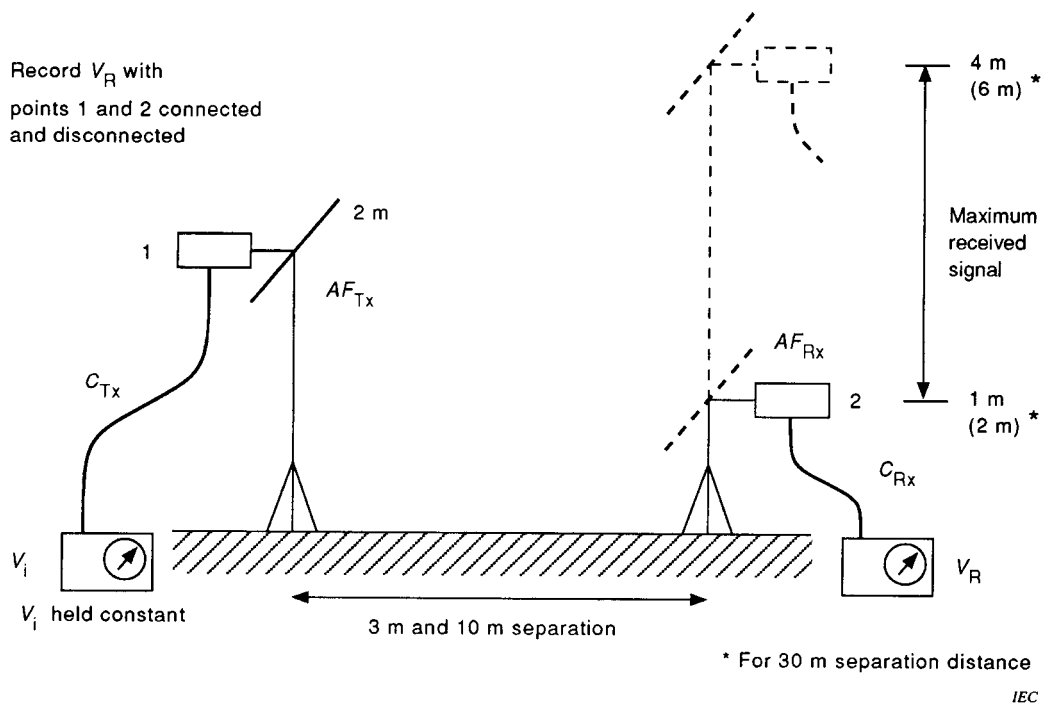

Figure 4 – Configuration of equipment for measuring horizontal polarization of site attenuation (see 5.6 and annex E)

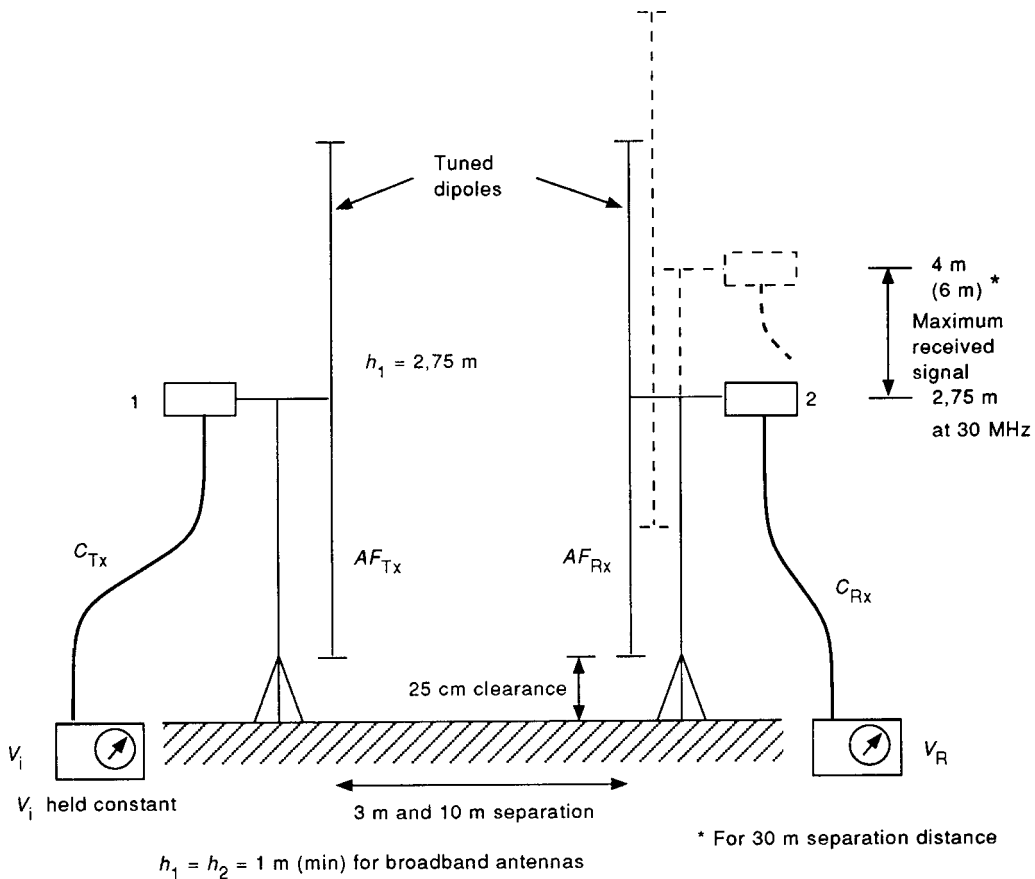

Figure 5 – Configuration of equipment for measuring site attenuation for vertically polarized using tuned dipoles (see 5.6 and annex E)

NSA for frequencies other than those shown in the tables may be found using straight-line interpolation between the tabulated values.

The legend for each table is as follows:

R Horizontal separation distance between the projection of the transmit and receive antennas on the ground plane (metres).

h_1 Height of the centre of the transmit antenna above the ground plane (metres).

h_2 Range of heights of the centre of the receive antenna above the ground plane (metres). The maximum received signal in this height scan range is used for NSA measurements.

f_m Frequency in MHz.

A_N NSA (see equation 1, below).

NOTE The spacing *R* between log-periodic array antennas is measured from the projection on to the ground plane of the mid-point of the longitudinal axis of each antenna.

It is recommended that horizontal NSA measurements be performed first. Since such measurements are less sensitive than that for vertical polarization in finding test anomalies, the measured NSA should readily be within ± 4 dB of that shown in tables E.1, E.2 and E.3. If not, recheck measurement technique, instrumentation drift and antenna factor calibrations. If the ± 4 dB criterion is still exceeded, a significant site anomaly is present which should be readily apparent and corrective action taken before proceeding to the vertical polarization NSA measurement.

5.6.1 General NSA measurement

For each polarization measurement, the NSA procedure requires two different measurements of V_R which is the voltage received. The first reading of V_R is with the two coaxial cables disconnected from the two antennas and connected to each other via an adapter. The second reading of V_R is taken with the coaxial cables reconnected to their respective antennas and the maximum signal measured when the receive antenna is scanned in height. (1-4 m for 3 m and 10 m separation distances and either 1-4 m or 2-6 m for the 30 m separation.) For both of these measurements, the signal source voltage, V_i , is kept constant. The first reading of V_R is called V_{DIRECT} and the second is V_{SITE} . These are used in the following equation (1) for the measured NSA, A_N ; all terms are in dB.

$$A_N = V_{DIRECT} - V_{SITE} - AF_T - AF_R - \Delta AF_{TOT} \quad (1)$$

where

AF_T is the transmit antenna factor;

AF_R is the receive antenna factor;

ΔAF_{TOT} is the mutual impedance correction factor.

Note that the first two terms represent the actual measurement of site attenuation, i.e., $V_{DIRECT} - V_{SITE}$ is equal to the classical view of site attenuation, which is constituted by the insertion loss of the propagation path with the inclusion of the properties of the two antennas used. Theoretical values for ΔAF_{TOT} are given in table E.4. AF_T and AF_R shall be measured.

Note that: $V_{DIRECT} = V_i - C_T - C_R$

where

C_T and C_R are the cable losses which do not need to be measured separately. The mutual impedance correction factor in table E.4 applies only to the recommended site geometry of 3 m separation, horizontal polarization and the use of half-wavelength tuned dipoles.

To accomplish these NSA measurements, two techniques can be used, depending on the instrumentation available and whether a broadband or tuned dipole is used. Both methods give essentially equal results if used correctly as outlined in annex E. Briefly, each method is described as follows:

a) Discrete frequency method

For this method, specific frequencies given in tables E.1, E.2 or E.3 are measured in turn. At each frequency the receive antenna is scanned over the height range given in the appropriate table to maximize the received signal. These measured parameter values are inserted in equation (1) to obtain the measured NSA. Annex E contains a suggested procedure approach to record the data, calculate the measured NSA, and then compare it with the theoretical NSA.

b) Swept frequency method

For this method, measurements using broadband antennas may be made using automatic measuring equipment having a peak hold (maximum hold), storage capability, and a tracking generator. In this method both antenna height and frequency are scanned or swept over the required ranges. The frequency sweep speed shall be much greater than the antenna height scan rate. Otherwise the procedure is the same as in a). A detailed procedure is given in annex E.

5.6.2 Antenna factor determination

Accurate antenna factors are necessary in measuring NSA. In general, antenna factors provided with the antenna are inadequate unless they are specifically or individually measured. Linearly polarized antennas are required. A useful antenna calibration method is contained in annex E. Manufacturer's antenna factors may account for losses due to the balun among other features. If a separate balun or any integrally associated cables are used, their effects must be accounted for. The formula to use for tuned half-wave dipoles is also contained in annex E.

5.6.3 Site attenuation deviations

If measurements of NSA deviate by more than ± 4 dB, several items should be re-checked first:

- a) measurement procedure;
- b) accuracy of antenna factors;
- c) drift in signal source or accuracy of receiver or spectrum analyzer input attenuator and reading.

If no errors are found in a), b) and c), then the site is at fault and detailed investigation of possible causes of site variability should be made. Annex F contains the errors that can occur with NSA measurements.

Note that since the vertical polarization is generally the more critical measurement, site anomalies should be investigated using this more sensitive measurement rather than the horizontal polarization results. Key items to investigate include:

- a) ground plane size and construction inadequacy;
- b) objects at the perimeter of the site that may be causing undesired scattering;
- c) all-weather cover;
- d) ground plane discontinuity at the turntable circumference when the turntable surface is conductive and at the same elevation as the ground plane;
- e) thick dielectric ground plane covers;
- f) openings in ground plane for stairways.

5.7 Test site suitability with ground-plane

There are many different test sites and facilities that have been constructed to make radiated emission measurements. Most are protected from the weather and the adverse effects of the radio frequency ambient. These include all weather-covered open area test sites and absorber-lined shielded rooms.

Whenever construction material encloses a test site, there is the possibility that the results of a single normalized site attenuation (NSA) measurement, as specified in 5.6, are not adequate to show such alternative site suitability.

To assess alternative test site suitability, the following procedure is recommended. It is based on making multiple NSA measurements throughout a volume occupied by the EUT. These NSA measurements shall all come within the error budget of ± 4 dB to be judged suitable as an equivalent to an open area test site.

The discussion in this section concerns alternative test sites which have a conducting ground plane.

5.7.1 Normalized site attenuation for alternative test sites

For an alternative test site a single NSA measurement is insufficient to pick up possible reflections from the construction and/or RF-absorbing material comprising the walls and ceiling of the facility. For these sites a "test volume" is defined as that volume traced out by the largest equipment or system to be tested as it is rotated about its centre location through 360°, such as by a turntable. In evaluating horizontal and vertical polarization, such as illustrated in figures 6a and 6b, it may require a maximum of 20 separate site attenuation measurements, i.e. five positions in the horizontal plane (centre, left, right, front, and rear, measured with respect to the centre and a line drawn from the centre to the position of the measuring antenna), for two polarizations (horizontal and vertical), and for two heights (1 m and 2 m horizontal, 1 m and 1,5 m vertical).

These measurements are carried out with a broadband antenna and distances are measured with respect to the centre of the antenna. The transmit and receive antennas shall be aligned with the antenna elements parallel to each other and orthogonal to the measurement axis.

For vertical polarization, the off-centre positions of the transmit antenna are at the periphery of the test volume. Furthermore, the lower tip of the antenna shall be greater than 25 cm from the floor, which may require the centre of the antenna to be slightly higher than 1 m for the lowest height measurement.

For horizontal polarization measurements in the left and right positions if the distance between the construction and/or absorbing material on the side walls and EUT periphery is less than 1 m, the centre of the antenna is moved towards to central position so that the extreme tip of the antenna is either at the periphery or distant from the periphery by not more than 10 % of the test volume diameter. The front and rear positions are at the periphery of the test volume.

The number of required measurements can be reduced under the following circumstances:

- a) The vertical and horizontal polarization measurements in the rear position may be omitted if the closest point of the construction and/or absorbing material is at a distance greater than 1 m from the rear boundary of the test volume.

NOTE Radiated emission sources located near dielectric interfaces have been shown to have variations in current distribution that can affect the radiated properties of the source at that location. When EUT can be located near these interfaces, additional site attenuation measurements are required.

- b) The total number of horizontal polarization measurements along the test volume diameter joining the left and right positions may be reduced to the minimum number necessary for the antenna footprints to cover 90 % of the diameter.
- c) The vertical polarization measurements at the 1,5 m height may be omitted if the top of the EUT, including any table mounting, is less than 1,5 m in height.
- d) If the test volume is no larger than 1 m in depth, by 1,5 m in width, by 1,5 m in height, including table if used, horizontal polarization measurements need only be made at the centre, front and rear positions but at the height of both 1 m and 2 m. If item a) above applies, the rear position may be omitted. This will require a minimum of eight measurements: four positions vertical polarization (left, centre, right, and front) for one height, and four positions horizontal polarization (centre and front) for two heights; see figures 6c and 6d.

NSA measurements shall be performed with the transmit and receive antenna separation held constant according to tables 1 and 2. Note that these tables have been modified to accommodate these NSA measurements by adding values for an additional transmit height and to limit the 30 m scan height to between 1 m and 4 m. The receive antenna must be moved to maintain the appropriate separation along a line towards the turntable centre (see figures 6a, 6b, 6c and 6d). The alternative test site is considered suitable for performing radiated emission testing if all NSA measurements prescribed above meet the requirements of 5.7.2 and the ground plane requirements of 5.7.3 below.

NOTE Studies are underway to determine if any further tests are required to show alternate test site suitability.

5.7.2 Site attenuation

A measurement site shall be considered acceptable for radiated electromagnetic field measurements if the measured horizontal and vertical NSA measurements are within ± 4 dB of the theoretical normalized site attenuation for an ideal site.

5.7.3 Conducting ground plane

A conducting ground plane is required at a radiated emission test site. The conducting ground plane shall extend at least 1 m beyond the periphery of the EUT and the largest measurement antenna, and cover the entire area between the EUT and the antenna. It shall be of metal with no holes or gaps having longitudinal dimensions larger than one-tenth of a wavelength at the highest frequency of measurement. A larger size conducting ground plane may be required if the NSA measurements do not meet the ± 4 dB criterion.

NOTE Ongoing studies may indicate the need for specifying minimum conductive ground plane size.

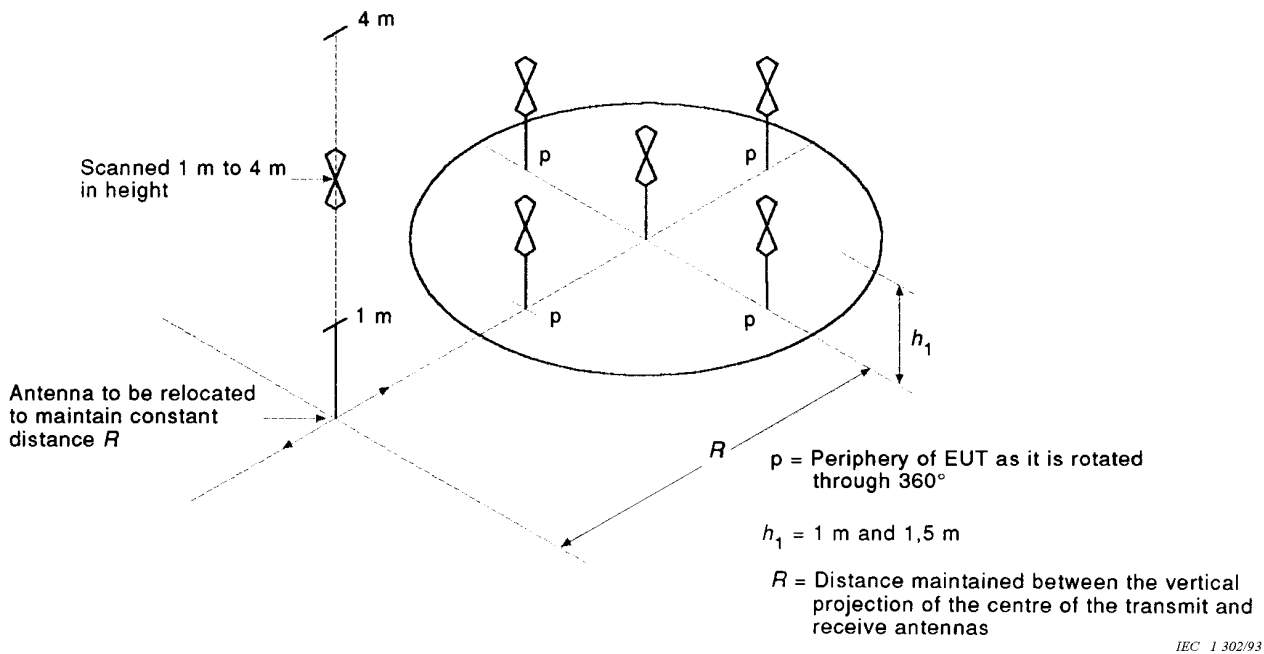

Figure 6a – Typical antenna positions for alternative test site – Vertical polarization NSA measurements

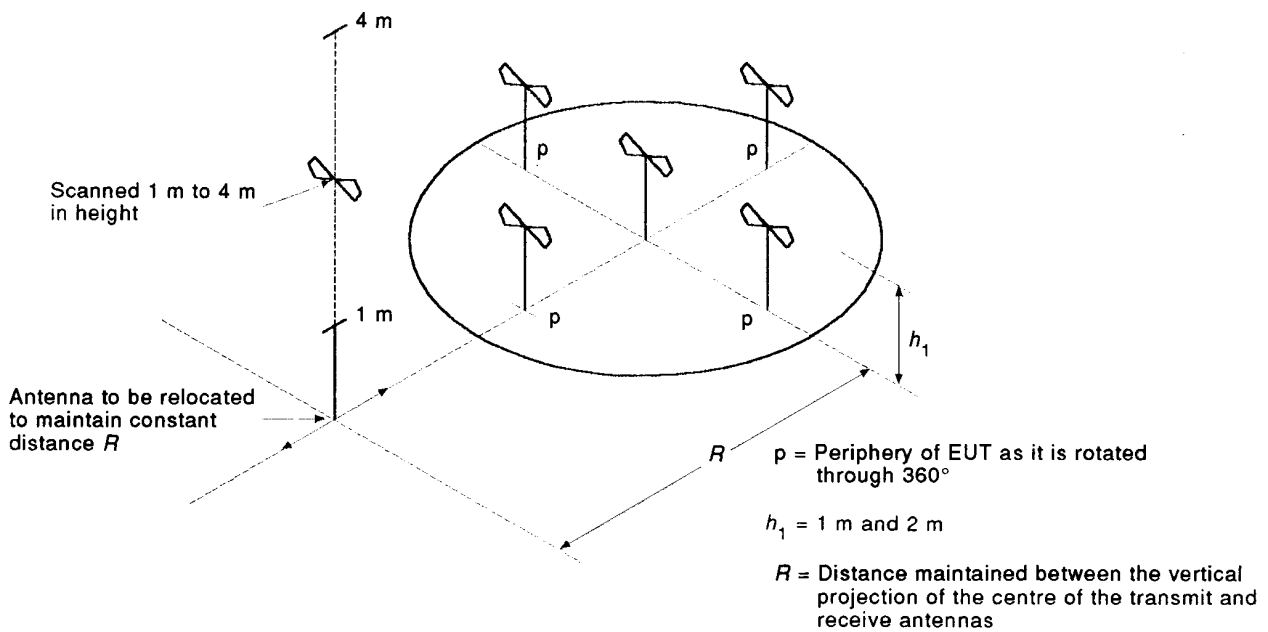
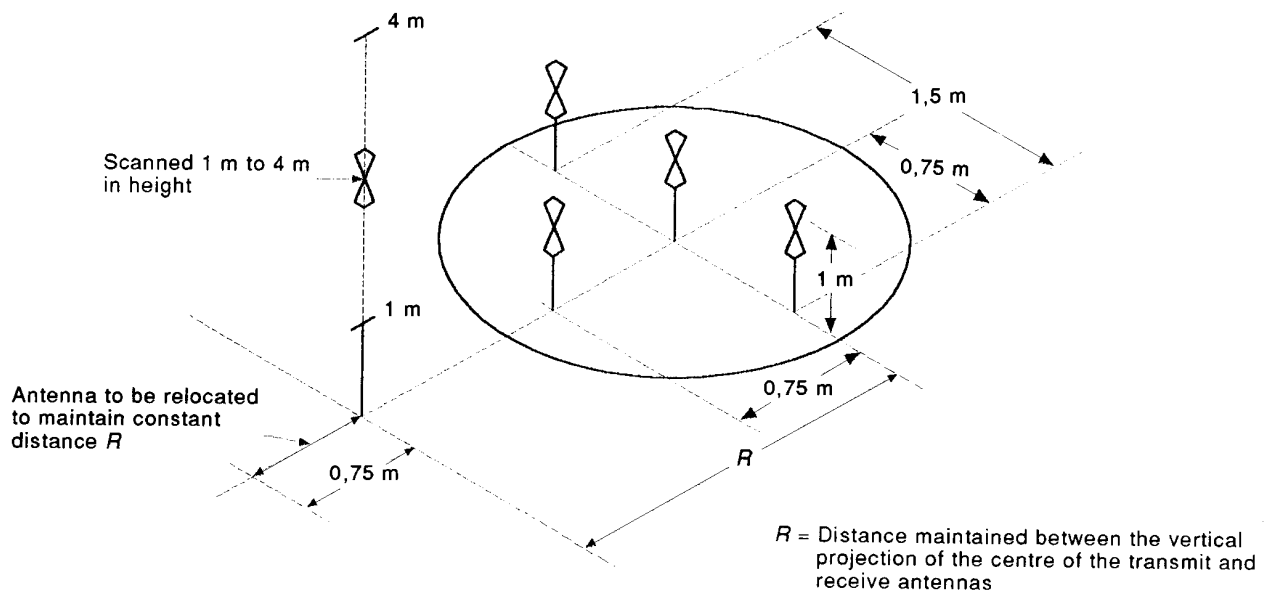
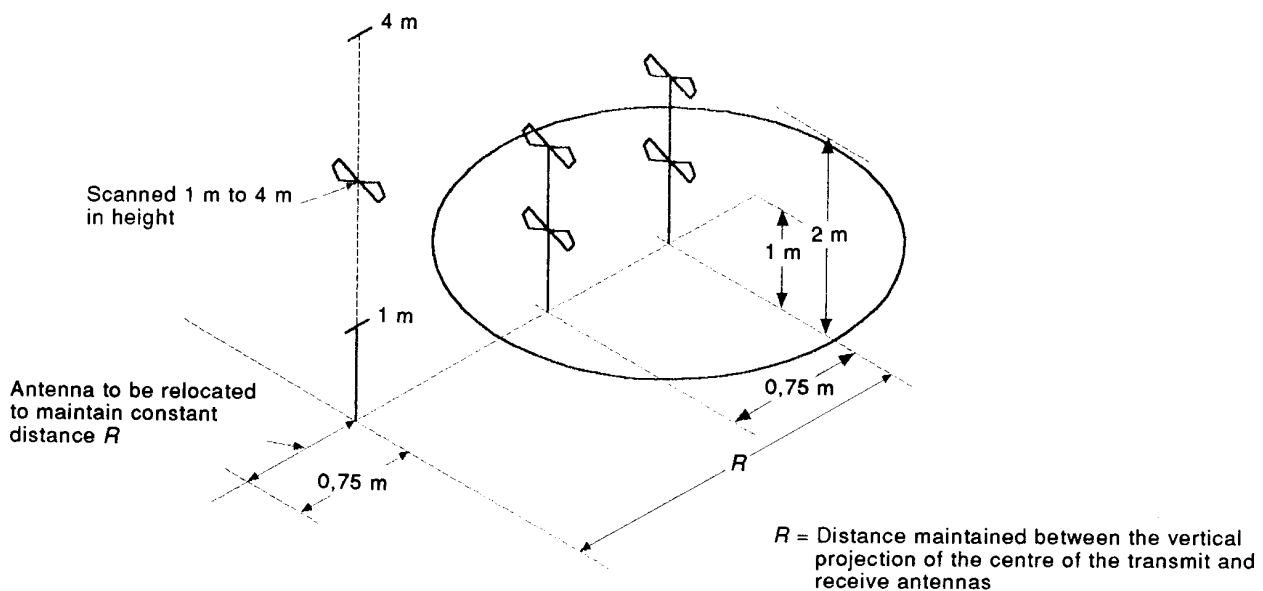

Figure 6b – Typical antenna positions for alternative test site – Horizontal polarization NSA measurements



IEC 1304/93

Figure 6c – Typical antenna positions for alternative test site – Vertical polarization NSA measurements for an EUT that does not exceed a volume of 1 m depth, 1,5 m width, 1,5 m height, with the periphery greater than 1 m from the closest material that may cause undesirable reflections



IEC 1305/93

Figure 6d – Typical antenna positions for alternative test site – Horizontal polarization NSA measurements for an EUT that does not exceed a volume of 1 m depth, 1,5 m width and 1,5 m height, with the periphery greater than 1 m from the closest material that may cause undesirable reflections

Figure 6 – Typical antenna positions for alternative test sites

**Table 1 – Normalized site attenuation
(recommended geometries for tuned half-wave dipoles with horizontal polarization)**

Polarization	Horizontal	Horizontal	Horizontal
<i>R</i>	3 m	10 m	30 m
<i>h</i>₁	2 m	2 m	2 m
<i>h</i>₂	1 m to 4 m	1 m to 4 m	1 m to 4 m
<i>f</i>_m MHz	<i>A</i>_N dB		
30	11,0	24,1	41,7
35	8,8	21,6	39,1
40	7,0	19,4	36,8
45	5,5	17,5	34,7
50	4,2	15,9	32,9
60	2,2	13,1	29,8
70	0,6	10,9	27,2
80	-0,7	9,2	24,9
90	-1,8	7,8	23,0
100	-2,8	6,7	21,2
120	-4,4	5,0	18,2
140	-5,8	3,5	15,8
160	-6,7	2,3	13,8
180	-7,2	1,2	12,0
200	-8,4	0,3	10,6
250	-10,6	-1,7	7,8
300	-12,3	-3,3	6,1
400	-14,9	-5,8	3,5
500	-16,7	-7,6	1,6
600	-18,3	-9,3	0
700	-19,7	-10,6	-1,4
800	-20,8	-11,8	-2,5
900	-21,8	-12,9	-3,5
1 000	-22,7	-13,8	-4,5

Table 2 – Normalized site attenuation*
(recommended geometries for broadband antennas)

Polarization	Horizontal	Horizontal	Horizontal	Vertical	Vertical	Vertical	Vertical
R	3 m	10 m	30 m	3 m	3 m	10 m	30 m
h_1	1 m	1 m	1 m	1 m	1,5 m	1 m	1 m
h_2	1 m to 4 m	1 m to 4 m	1 m to 4 m	1 m to 4 m	1 m to 4 m	1 m to 4 m	1 m to 4 m
f_m MHz	A_N dB						
30	15,8	29,8	47,8	8,2	9,3	16,7	26,0
35	13,4	27,1	45,1	6,9	8,0	15,4	24,7
40	11,3	24,9	42,8	5,8	7,0	14,2	23,5
45	9,4	22,9	40,8	4,9	6,1	13,2	22,5
50	7,8	21,1	38,9	4,0	5,4	12,3	21,6
60	5,0	18,0	35,8	2,6	4,1	10,7	20
70	2,8	15,5	33,1	1,5	3,2	9,4	18,7
80	0,9	13,3	30,8	0,6	2,6	8,3	17,5
90	-0,7	11,4	28,8	-0,1	2,1	7,3	16,5
100	-2,0	9,7	27	-0,7	1,9	6,4	15,6
120	-4,2	7,0	23,9	-1,5	1,3	4,9	14,0
140	-6,0	4,8	21,2	-1,8	-1,5	3,7	12,7
160	-7,4	3,1	19	-1,7	-3,7	2,6	11,5
180	-8,6	1,7	17	-1,3	-5,3	1,8	10,5
200	-9,6	0,6	15,3	-3,6	-6,7	1,0	9,6
250	-11,7	-1,6	11,6	-7,7	-9,1	-0,5	7,7
300	-12,8	-3,3	8,8	-10,5	-10,9	-1,5	6,2
400	-14,8	-5,9	4,6	-14,0	-12,6	-4,1	3,9
500	-17,3	-7,9	1,8	-16,4	-15,1	-6,7	2,1
600	-19,1	-9,5	0	-16,3	-16,9	-8,7	0,8
700	-20,6	-10,8	-1,3	-18,4	-18,4	-10,2	-0,3
800	-21,3	-12,0	-2,5	-20,0	-19,3	-11,5	-1,1
900	-22,5	-12,8	-3,5	-21,3	-20,4	-12,6	-1,7
1 000	-23,5	-13,8	-4,4	-22,4	-21,4	-13,6	-3,5

* This data applies to antennas that have at least 25 cm of ground plane clearance when the centre of the antennas is 1 m above the ground plane in vertical polarization.

5.8 Test site suitability without ground-plane

The procedure for test sites without ground-plane in the frequency range 30 MHz to 1 000 MHz is as follows.

5.8.1 Measurement considerations for free space test sites, as realized by fully absorber-lined shielded enclosures

A fully absorber lined shielded enclosure, also known as a fully anechoic chamber (FAC), or a fully anechoic room (FAR), may be used for radiated emission measurements. When the FAR method is used, appropriate radiated emission limits shall be defined in relevant standards (generic, product or product family standards). Compliance with the radio services protection requirements (limits) shall be established for FARs in a similar way as for tests on an OATS.

A FAR is intended to simulate a free space environment such that only the direct ray from the transmitting antenna or EUT reaches the receiving antenna. All indirect and reflected waves shall be minimized with the use of appropriate absorbing material on all walls, the ceiling and the floor of the FAR.

5.8.2 Site performance

Site performance may be validated by two methods which are described below – the site reference method and the NSA method.

5.8.2.1 Theoretical normalized site attenuation

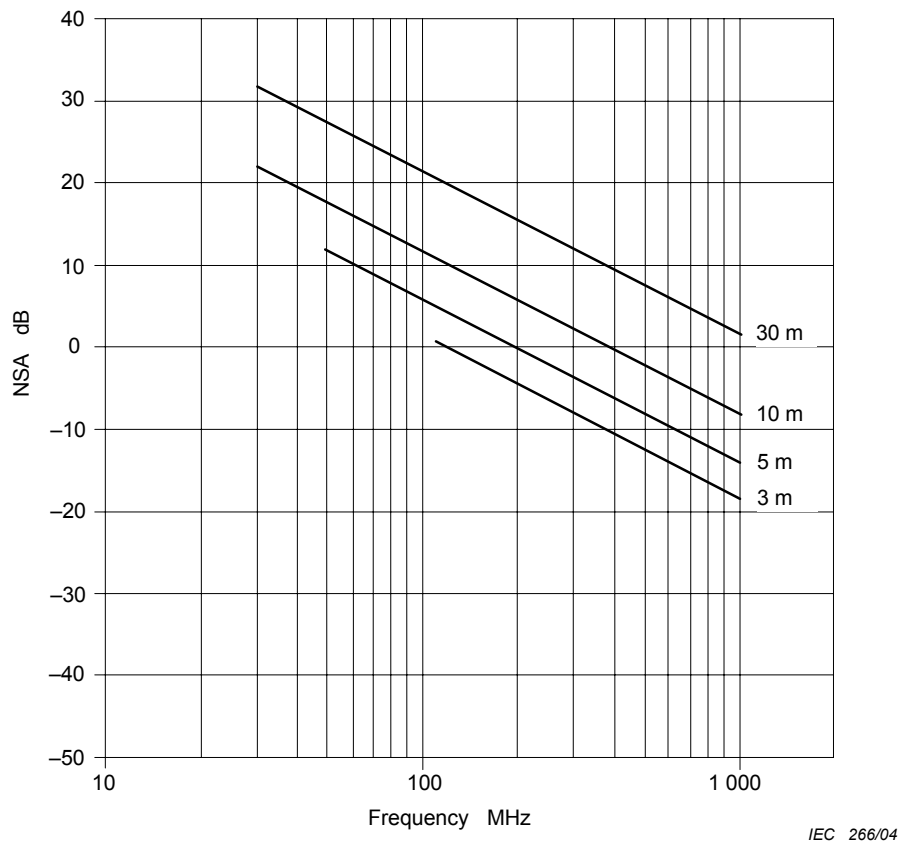

Figure 9 – Graph of theoretical free-space NSA as a function of the frequency for different measurement distances (see equation 4)

NOTE Frequencies below 110 MHz for 3 m measurement and below 60 MHz for 5 m measurement distances include near field effects. These must be calculated for each individual test site.

The following describes the NSA theory for infinitely small antennas.

Site attenuation (SA) is the transmission loss measured between the connectors of two antennas on a particular site. For a free space environment, SA (in dB) can be approximated by Equation (2)¹⁾

$$SA = 20\log_{10} \left[\left(\frac{5Z_0}{2\pi} \right) \left(\frac{d}{\sqrt{1 - \frac{1}{(\beta d)^2} + \frac{1}{(\beta d)^4}}} \right) \right] - 20\log_{10} f_m + AF_R + AF_T \quad (2)$$

where

AF_R, AF_T are the antenna factors of the receive and transmit antennas in dB/m;
 d is the distance between the phase centres of both antennas in metres;
 Z_0 is the reference impedance (i.e. 50 Ω);
 β is defined as $2\pi / \lambda$; and
 f_m is the frequency in MHz.

The theoretical normalized site attenuation (NSA) in dB is defined as site attenuation with respective antenna factors subtracted, thus:

$$NSA_{\text{calc}} = 20\log_{10} \left[\left(\frac{5Z_0}{2\pi} \right) \left(\frac{d}{\sqrt{1 - \frac{1}{(\beta d)^2} + \frac{1}{(\beta d)^4}}} \right) \right] - 20\log_{10} f_m \quad (3)$$

Below 60 MHz at a 5 m distance or 110 MHz at a 3 m distance, it is necessary to apply near field correction factors for each of the required test positions of Table 3 for comparison with the theoretical NSA of Figure 9 and Equation (2). Near field correction factors are specific to the antennas, test distance, and test volume used, and therefore must be obtained by using a numerical modelling code such as NEC. Alternatively the site reference method of 5.8.2.2.1 provides cancellation of near field terms if the same antennas and frequencies are used for both the site reference measurement and FAR validation.

For measurement distances of 10 m and 30 m, the near-field terms in Equation (3) may be omitted, and the equation simplifies as follows:

$$NSA_{\text{calc}} = 20\log_{10} \left[\frac{5Z_0 d}{2\pi} \right] - 20\log_{10} f_m \quad (4)$$

¹⁾ Reference: GARBE, H. New EMC Test Facilities for Radiation Measurements. *Review of Radio Science 1999-2002*. John Wiley & Sons, New York, 2002

If simplified Equation (4), is used instead of Equation (2) the error introduced is less than 0,1dB at frequencies above 60 MHz for 5 m distance and above 110 MHz for 3 m distance. The error will be >0,1 dB below these frequencies due to near-field effects. For a 3 m distance the maximum error is 1 dB at 30 MHz. To reduce this error Equation (2) should be used.

5.8.2.2 Site validation procedure

The NSA shall satisfy the requirement of 5.8.3 over a cylindrical test volume generated by the rotation of the EUT on the turntable. In this context “the EUT“ includes all components of a multi-unit EUT and the interconnecting cables. Table 3 defines the maximum height and diameter ($h_{\max} = d_{\max}$) of the test volume as a function of test distance. This ratio between diameter and test distance ensures an acceptable uncertainty in EUT emissions testing.

Table 3 – Maximum dimensions of test volume versus test distance

Maximum diameter d_{\max} and height h_{\max} of the test volume m	Test distance D_{nominal} m
1,5	3,0
2,5	5,0
5,0	10,0

A single position SA (site attenuation) measurement may not be sufficient to pick up possible reflections from the room construction and/or absorbing material lining the walls, floor, ceiling and turntable of the FAR.

The fully anechoic room SA measurements and validation shall therefore be performed at 15 measurement positions for both horizontal and vertical antenna polarizations of the transmit antenna in the test volume (see Figure 10):

- at three heights of the test volume: bottom, middle and top;
- at 5 positions in all 3 horizontal planes: centre, left, right, front and rear positions in each horizontal plane. The rear position may be omitted if the distance between rear position and absorbers is more than 0,5 m. During EUT testing, the rear position on the turntable is also turned to the front, and the contribution of the back reflection will then not affect the maximum signal.

For SA measurements two broadband antennas shall be used: one transmit antenna with its reference point at the measurement positions of the test volume and one receive antenna outside this test volume at a prescribed orientation and position. The transmit antenna shall have an approximately omni-directional H -plane pattern. (The maximum dimension shall not exceed 40 cm for a 3 m test distance; at larger distances, the size of the antenna can be scaled accordingly).

Typical receive antennas are hybrid (biconical/LPD combination) antennas for 30 MHz to 1 000 MHz, or separate [biconical antennas (for 30 MHz to 200 MHz) and LPD antennas (for 200 MHz to 1 000 MHz)].

NOTE Use of a hybrid (biconical/LPD combination) antenna is not recommended for either emission testing or chamber validation at 3 m distance, due to the large physical size of such antennas.

The same antennas, cables, ferrites, attenuators, amplifier, signal generator and receiver used to measure the SA of the FAR, shall be used to measure the reference SA on the quasi-free space test site (5.8.2.2.2). The receive antenna used during the room validation shall be of the same type as used during radiated emission testing of the EUT.

For test volume validation both in horizontal and vertical polarization, and for all transmitting antenna positions in the test volume, the position in height of the receiving antenna in the FAR shall be set and remain at the fixed middle level of the test volume, as shown in Figures 10 and 11. Tilting the antennas shall be necessary to align the bore sight axis of both antennas in one measurement axis. The distance between the antenna reference point (defined in antenna calibration) and the front position of the test volume is $d_{nominal}$. When the transmit antenna is moved to other positions in the test volume, the receive antenna shall be translated along the measurement axis to maintain $d_{nominal}$. The measurement axis is the line between the transmit and receive antenna, along which $d_{nominal}$ is defined. For all positions and polarizations, the receiving and the transmitting antenna must face one another with the elements of both antennas parallel (tilting, see Figure 11). Any antenna masts and the supporting floors shall be in place during the validation procedure.

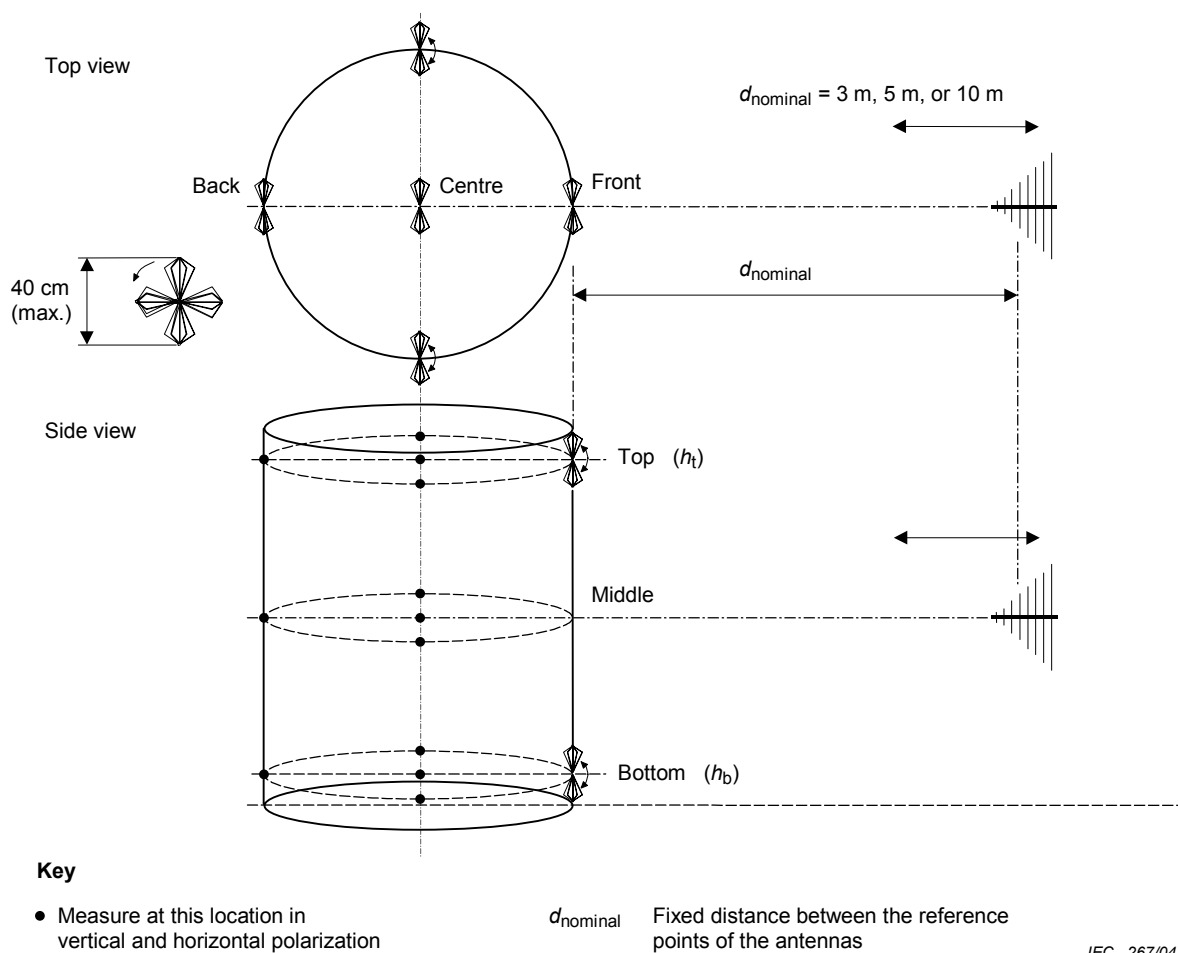

Figure 10 – Measurement positions for the site validation procedure

For all positions of the transmitting antenna in the test volume, in both horizontal and vertical polarizations, the transmitting and receiving antennas shall be aligned on the measurement axis.

Tilting the antennas is necessary to meet this requirement at certain positions (see Figure 11).

$d_{nominal}$ { is the test distance associated with the limit;
is the fixed antenna distance in the validation procedure;
is the antenna separation in the antenna calibration procedure.

The transmit antenna height position in the test volume shall be determined as follows:

- "Middle" where possible along a virtual axis positioned at mid-height and mid-width of the FAR;
- "top (h_t)" and "bottom (h_b)" by half of h_{max} (see Table 3) minus half of the transmit antenna dimension (e.g. 20 cm for small biconical antenna).

These adjusted positions shall be used for both vertical and horizontal polarizations. The distance between the top and bottom planes and the ceiling and floor absorbers respectively is given by the absorber performance as determined by the volumetric NSA test, but at least 0,5 m, to avoid EUT to absorber coupling.

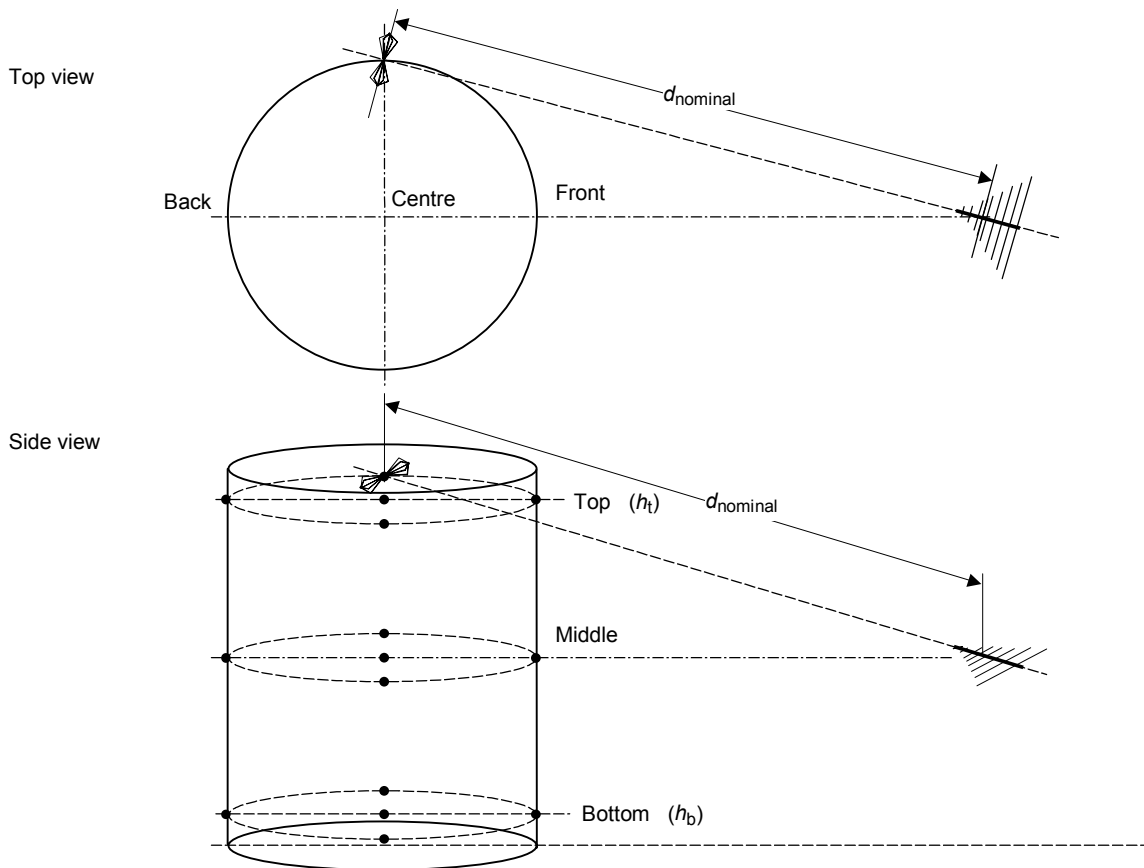

IEC 268/04

NOTE Antenna polarization horizontal, position top right.

Figure 11 – Example of one measurement position and antenna tilt for the site validation procedure

The maximum step size for the discrete-frequency measurement shall be as listed in Table 4:

Table 4 – Frequency ranges and step sizes

Frequency range MHz	Maximum frequency step MHz
30 – 100	1
100 – 500	5
500 – 1 000	10

Two methods are permissible for site validation:

- a) the site reference method, which is required for test distances less than 5 m;
- b) the *NSA* method, which is preferred for test distances greater than or equal to 5 m.

The *SA* measurement methods are intended to provide 0 dB deviation when performed on an ideal site. Any methods may be implemented to decrease measurement uncertainty, as long as these do not contradict the defined set-up and procedures or hide any site deficiencies, e.g. smoothed resonances.

Site validation measurement uncertainty can be decreased by the following measures.

- For a vertically-polarized antenna, shielded cables are to be extended by at least 2 m behind each antenna before dropping the cable to the ground. If possible, cables shall extend straight back to the bulkhead connectors in the wall of the room. Another possibility is the use of clip-on ferrites on the cables. Another alternative for reducing the influence of cables is through the use of optical links.
- Attenuators at the antenna connectors (e.g. 6 dB or 10 dB) will reduce the influence of any large impedance mismatch at the antennas.
- Antennas with good balance of the balun shall be used (the receiver reading changes less than $\pm 0,5$ dB when the antenna is rotated through 180 degrees with respect to its bore sight axis. Antenna balance verification methods are described in 4.4.2).
- Separate biconical and LPD antennas for chamber evaluation may be used (antenna type is changed at 200 MHz), if these will be used for EUT testing. A hybrid (biconical/LPD combination) antenna is a combination of these two types and may be used as well if the mechanical dimensions are sufficiently small for the measurement distance.

The FAR site validation procedure shall be performed at regular intervals, to detect long-term changes in room characteristics, and when changes that might influence the electromagnetic wave transmission characteristics in the fully anechoic room occur.

5.8.2.2.1 The site reference method

SA measurements with the antenna pair (transmit and receive antenna) on a quasi-free space test site are required as a reference. The procedure for determining this reference site attenuation (SA_{ref}) is described in 5.8.2.2.2. This method accounts for mutual coupling of the antennas and near field effects, which can have a significant influence at 3 m test distances. The reference site attenuation $SA_{ref}(d)$ is performed at the nominal distance, $d_{nominal}$, between the transmit and receive antennas.

The site validation procedure for each test volume position is performed in three steps.

- 1) $M0$ is the reference level measured by the receiver in $\text{dB}\mu\text{V}$ with the cables connected together, normally done once before a series of volumetric tests.
- 2) $M1$ is the level measured by the receiver in $\text{dB}\mu\text{V}$ with antennas installed.

The site attenuation of the validated site SA_{val} can be calculated by

$$SA_{val} = M0 - M1 \quad \text{in dB} \quad (5)$$

- 3) The deviation of the measured site attenuation (ΔSA) from reference site attenuation $SA_{ref}(d)$ is calculated using Equation (6).

$$\Delta SA = SA_{ref}(d) - SA_{val} \quad \text{in dB} \quad (6)$$

5.8.2.2.2 Determining the site reference

For accurate site validations at distances less than 5 m, it is recommended that dedicated pairs of antennas be used to determine the site reference (transmit and receive antenna). A quasi-free space test site is required. It consists of 2 non-metallic antenna masts (wood or plastic with $\epsilon_r \leq 2,5$, low loss, diameter as small as possible retaining mechanical strength), which allow the placement of antennas at a certain height above the ground level (Figure 12). One possible method of realization of the ± 1 dB performance of the reference site is to choose the height (h) of the antennas as follows

$$h \geq d \times 8/3 \quad (7)$$

where d is the antenna separation.

A height of $h = d \times 8/3$ is recommended to suppress the influence of the ground, or substantial absorbers which work down to 30 MHz, need to be placed on the ground.

NOTE At 3 m separation at 30 MHz there is a significant near field term ($1/d^2$) that alone contributes an error of 0,8 dB for a height of $5/3$. This was verified by the national laboratories of both the UK and Austria. For a site reference with an uncertainty of less than $\pm 0,5$ dB a height of $8/3$ is recommended if no absorber is placed at the ground.

The distance shall be equal to the actual distance $d_{nominal}$ between the antennas used in the FAR. The antennas are polarized vertically (horizontal polarization shall not be used because of stronger interference with the ground-reflected signal). It also provides a good approximation of free-space. The clearance from buildings, trees, etc. shall be greater than $d \times 8/3$ because there may be an influence for vertically polarized antennas.

Care has to be taken that the antenna feed cables do not affect the test result. This is best avoided by a cable arrangement as shown in Figure 12, or using RF-optical links.

The quality of the reference set-up directly influences the FAR evaluation result.

The site reference (SA_{ref}) is determined in 3 steps, as follows.

- 1) $M0_{RS}$ is the reference level measured by the receiver in $\text{dB}\mu\text{V}$ with the cables connected together.
- 2) $M1_{RS}(d)$ is the level measured by the receiver in $\text{dB}\mu\text{V}$ with the antennas installed at the required distance $d_{nominal}$.
- 3) The $SA_{ref}(d)$ is calculated according to Equation (8)

$$SA_{ref}(d) = M0_{RS} - M1_{RS}(d) \text{ in dB} \tag{8}$$

For 3 m site validation a height of at least 4 m above ground shall be used, which is a typical capability of remotely controllable antenna masts that are used for emission measurements. In this case, electromagnetic absorbers shall be placed on the ground between the antennas, with the absorber patch extending for a minimum area beyond the antennas in all directions and it must be proven that quasi-free space condition, as defined in 5.8.1, is fulfilled. For site validation with $d > 3 \text{ m}$, the equation $h > d \times 8/3$ is used, or an alternative set-up that has been demonstrated to fulfill the $\pm 1 \text{ dB}$ reference site attenuation.

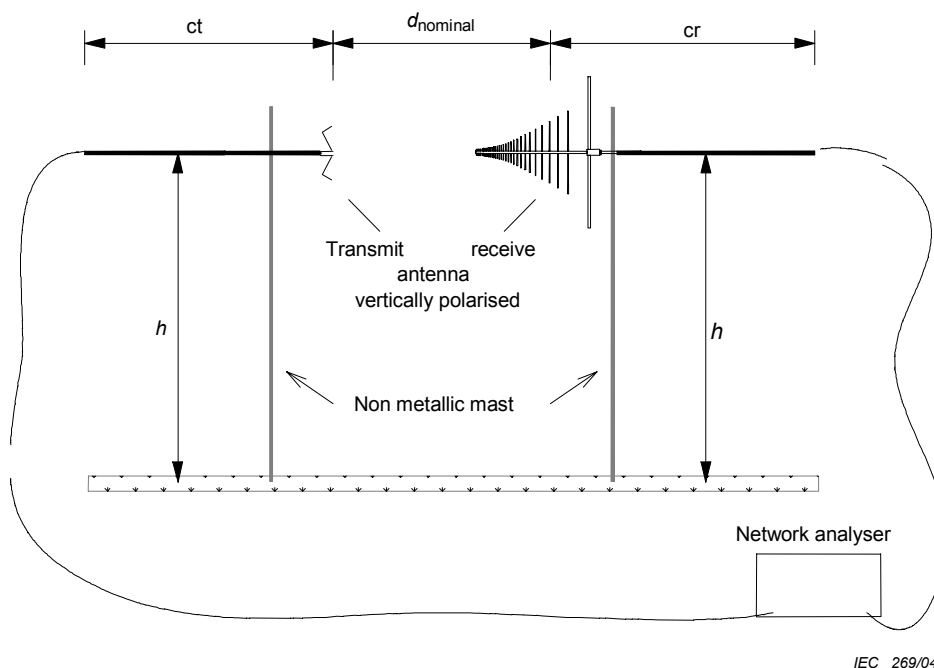

Key

- $d_{nominal}$ validation distance
- h height of the antennas above a ground plane or above ground level.
- ct, cr coaxial feed cables for transmit and receive antenna oriented horizontally behind the antenna for a distance as close to 2 m as physically possible. In a FAR, route the cables horizontally as far as possible, preferably straight through a hole in the chamber wall, or use optical fibre connected to an RF-optical link on the output of the antenna.

NOTE Site reference is obtained separately for all geometries of Figure 10.

Figure 12 – Typical free-space site reference measurement set-up

5.8.2.2.3 The NSA method

The free space antenna factors of the transmit and receive antenna (defined by antenna calibration clauses of the CISPR 16 series) are required for this procedure. The site validation for each measurement position is performed in 4 steps as follows.

- 1) M_0 is the reference level measured by the receiver with the cables connected together.
- 2) M_1 is the level measured by the receiver with the antennas installed.
- 3) The measured NSA (NSA_m) is calculated in dB according to Equation (9)

$$NSA_m = M_0 - M_1 - AF_T - AF_R \text{ in dB} \quad (9)$$

where AF_T and AF_R are free space antenna factors in dB/m.

- 4) The deviation ΔNSA is calculated in dB according to Equation (10)

$$\Delta NSA = NSA_m - NSA_{calc} \quad (10)$$

where NSA_{calc} is calculated using Equation (4), and ΔNSA is compared with the applicable NSA criterion, e.g. ± 4 dB, as specified in 5.8.3.

NOTE The distance d between the reference points of the transmit and receive antennas (defined by antenna calibration) must be used as $d_{nominal}$. The effective distance between the antennas varies with frequency due to their phase centre positions. The transmission loss shall be compensated by the ratio of the effective distance to $d_{nominal}$.

5.8.3 Site validation criteria

A measurement site shall comply with the following requirements:

- deviations of the SA or the NSA (Equation 6 or Equation 10) shall be less than ± 4 dB for both horizontal and vertical polarization and for each measurement position and measurement frequency;
- the uncertainty budget of the site evaluation according to CISPR 16-4-2 recommendations must be reported and shall have the same components as required for field strength measurements on alternative test sites with ground plane.

6 Reverberating chamber for total radiated power measurement

For some types of equipment operating in the microwave frequency range, because of the existence of complex three-dimensional radiation patterns which are sensitive to equipment operating conditions and its surroundings, the measurement of total radiated power is considered to be a significant parameter related to disturbance control. It can be measured by placing the equipment in a suitable chamber with metal walls. To avoid effects of standing waves that would otherwise produce non-uniform distribution of energy density with position in the chamber, rotating stirrers are installed. With proper size, shape and position, the energy density at any position in the chamber varies randomly with a constant statistical distribution law in phase, amplitude and polarization.

6.1 Chamber

6.1.1 Size and shape

The linear dimensions of the chamber shall be large relative to the wavelength of the lowest frequency of interest. It shall also be large enough to accommodate the equipment under test, the stirrers and the measuring antennas. Microwave equipment varies in size from the small table top oven having a volume of about 0,2 m³ to large units 1,7 m high with a 760 mm base. The chamber may be of any shape provided its three dimensions are of the same order. The three dimensions should preferably be different. For a lowest frequency of 1 GHz, the chamber shall have a volume at least 8 m³. The actual dimensions will depend on the physical characteristics of the chamber. See 6.1.4 for method of test of the suitability of the chamber.

The walls and the stirrers shall be metallic. Joints between the metallic members shall be mechanically sound and of low electrical resistance along the whole length, and there shall be no surface corrosion. No absorbing material, such as wood, shall be placed inside the chamber.

6.1.2 Door, openings in walls, and mounting brackets

The enclosure door shall be large enough to allow the passage of operators and equipment. It shall open outward, and fit tightly to minimize energy losses. For convenience in mounting, transmitting and receiving antennas inside the chamber, mounting brackets may be fixed to the walls.

6.1.3 Stirrers

The following describes two examples of stirrers. Other shapes are permissible provided stirring efficiency meets the criteria in 6.1.4.

6.1.3.1 Rotating vanes

If rotating vanes are used, two vanes are placed on adjacent walls of the chamber spaced at least 1/4 of the maximum wavelength used from the walls and of sufficient thickness to be rigid. They shall be of the maximum length allowed by the wall sizes and their width shall be about 1/5 of the length.

6.1.3.2 Rotating paddles

If rotating paddles are used, two or three paddles are mounted on the walls of the chamber. The paddles shall be mutually at right angles. The paddles may be of the shape shown in figure 7 and rotate about an axis parallel to their length. The diameter of the swept tubular space shall be at least equal to the maximum wavelength used, and the lengths shall be the maximum allowed by the wall sizes. The structure shall be rigid.

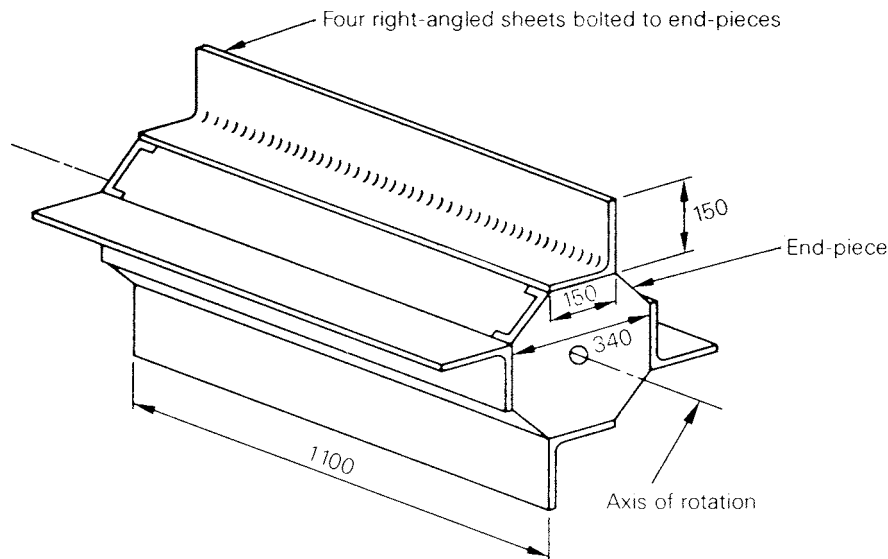

IEC 1307/99

Dimensions in millimetres

Figure 7 – Example of a typical paddle stirrer

6.1.3.3 Rotating speed

The rotation speeds of the stirrers shall be different. The longest time for one rotation of the stirrers shall be less than 1/5 of the integrating time of the measuring instrument. For the measuring equipment described in 6.1.5, a suitable rate is between 50 rev/min and 200 rev/min. The motors used to rotate the stirrers, together with their reduction gear, should preferably be outside the walls of the chamber.

6.1.4 Test for the efficiency of the stirrers

The desired uniform distribution of energy in the chamber is shown by the smoothness of the variation with frequency of coupling attenuation (described in 6.1.5). At low frequencies, due to the longer wavelengths, it is more difficult to achieve this uniformity and there exist pronounced maxima and minima. The greater the efficiency of the stirrers the smaller are these maxima and minima and hence the usable frequency is lower.

The coupling attenuation is measured over the usable frequency range of the chamber. At the lower frequencies where the maxima and minima are observable, values shall be measured at about 100 MHz intervals. The receiving antenna then remains fixed, the transmitting antenna is rotated at 45-degree intervals and the test is repeated for each position and at each frequency. The whole test shall be repeated again with the receiving antenna rotated at 90 degrees. The stirrers are considered satisfactory when: (1) the envelope of the graph of the maxima and the minima does not exceed 2 dB in any position of the transmitting antenna, and, (2) the means of the four graphs are within an envelope of 2 dB or less. Figure 8 shows a typical result.

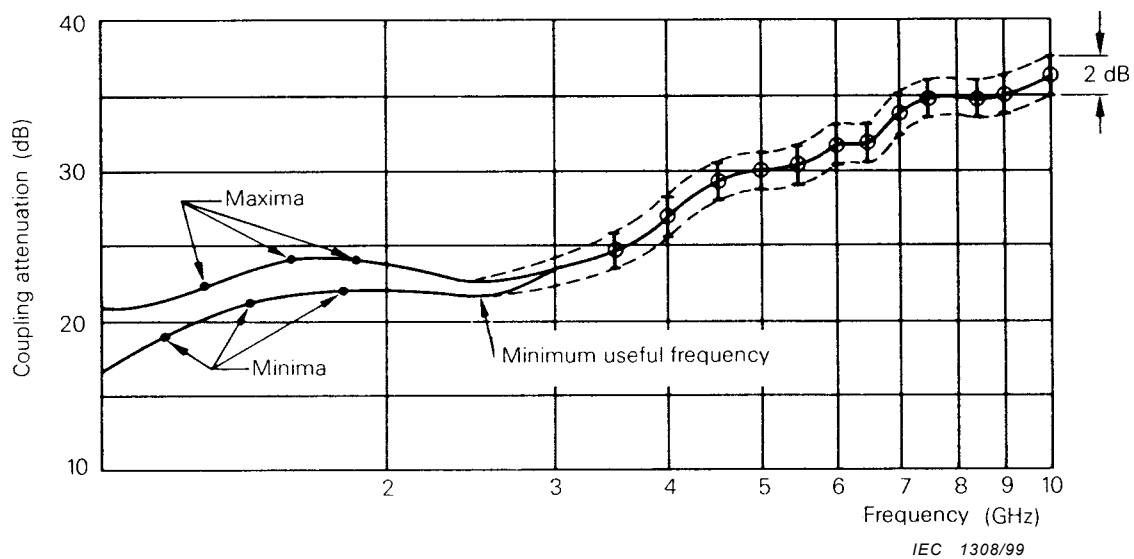

NOTE All measured points should lie inside the 2 dB envelope marked by dotted line.

Figure 8 – Range of coupling attenuation as a function of frequency for a chamber using the stirrer in figure 7

6.1.5 Coupling attenuation

The coupling attenuation of a chamber is the insertion loss measured between the terminals of the transmitting and the receiving antennas in the chamber. A calibrated signal generator whose power output can be accurately measured is used to feed power to a low-loss transmitting antenna (e.g. a horn antenna) located inside the chamber or on a chamber wall. A receiving antenna may be placed at any point in the chamber provided it is at least $1/4$ wavelength from the walls and not pointing toward the transmitting antenna, towards the nearest chamber wall, or aligned with any of the chamber axis.

A low-noise RF amplifier is connected to the receiving antenna via a high-pass filter; its output is connected through a band-pass filter to a diode detector. The band-pass filter shall be tuned to the frequency of interest and be of the specified bandwidth. The output of the detector is connected to a peak reading voltmeter with a specified peak-hold time (the hold time will depend on the equipment being measured). A spectrum analyzer may also be used for this measurement. The power absorbed by the transmitting antenna, P , is noted. The signal generator is then connected to the input of the low-noise amplifier, and its power output, p , is adjusted to give the same voltmeter reading. The power absorbed by the low-noise amplifier is noted. The coupling attenuation is $10 \lg (P/p)$ dB.

7 TEM cells for immunity to radiated disturbance measurement

(under consideration)

8 Test sites for measurement of radio disturbance field strength for the frequency range 1 GHz to 18 GHz

The test site shall rely on reflection-free conditions. It may be necessary to use absorbing material and/or to raise the height of the EUT to achieve these free-space conditions.

NOTE In the case of floor standing equipment tests, reflection-free conditions may not be achieved close to the ground.

8.1 Reference test site

The reference test site shall be a free-space, open area test site (FSOATS) with precautions to ensure that reflections do not influence the measurement.

8.2 Validation of the test site

The procedure to be used to validate the test site and the allowed tolerance with regard to the ideal free-space conditions for a site to be accepted (e.g. 4 dB as currently specified below 1 GHz or a lower value) is under consideration.

8.3 Alternative test site

Any measurement site that achieves free-space conditions is a possible alternative test site.

Annex A (normative)

Parameters of broadband antennas

A.1 Introduction

As new and improved antennas are used in making both radiated emission and immunity measurements over wide frequency ranges using scanning receivers or spectrum analyzers, it is very helpful to provide specific parameters that can be used in comparing the attributes and usefulness of such broadband antennas. Various CISPR publications specify particular antennas to be used in making measurements. Tuned half-wave resonant dipoles are most notably mentioned above 80 MHz. Generally, other types of antennas, normally broadband in nature, can be used provided the results are equivalent to those obtained with the specified antenna. The comparison of these broadband antennas to the specified antennas or to other broadband antennas will be aided by listing appropriate parameters. These parameters shall be specified as part of any CISPR contribution recommending new antenna usage. Antenna manufacturers shall also use this information as guidance in specifying the most useful aspects of broadband antennas used in making interference measurements. It is not the intent of CISPR, however, to show a preference for any particular broadband antenna over that for tuned dipoles.

A.2 Broadband antenna parameters

Broadband antennas used for CISPR measurements are those antennas that are linearly polarized and are intended for use over a wide frequency range. This does not prevent the use of antennas with limited length adjustment nor the addition of antenna element sections. The impedance of such antennas are typically comprised of both real and imaginary impedances. Other parameters that can be specified are contained below.

A.2.1 Antenna type

The following parameters describe the physical parameters of broadband antennas that should be provided. Note that some parameters may not apply to each antenna.

A.2.1.1 Antenna style of fixed or variable length or diameter

If the antenna has a variable length, specify the number of sections that are added or subtracted to change the basic fixed length.

NOTE Fully tunable antennas are not considered to be broadband and hence would not be specified herein. The diameter of loop antennas are generally not variable.

A.2.1.2 Depth to width ratio or loop diameter

Provide dimension in metres. For a log periodic array, for example, the length of the boom along the measurement axis and the width of the largest element would be provided.

A.2.1.3 Active or passive antenna

A broadband antenna is considered an active antenna if it contains amplifiers, preamplifiers, and other non-linear active devices which amplify the signal and or shape the frequency response.

A.2.1.4 Mounting arrangement

Provide any special mounting requirements beyond those which can be accommodated by a typical tripod or antenna positioner.

A.2.1.5 Connector type

Specify BNC, N, SMA, etc. as appropriate.

A.2.1.6 Balun type

Specify if balun is discrete, distributed, tunable, etc.

A.2.2 Specification of the antenna**A.2.2.1 Frequency range**

Specify the frequency range in megahertz or kilohertz where the antenna operates within its characteristics. If there is a defined fall-off characteristic in decibels per octave at either end of the range, so specify.

A.2.2.2 Gain and antenna factor**A.2.2.2.1 Gain**

Specify typical or actual gain in decibels relative to an isotropic radiator (dBi).

A.2.2.2.2 Antenna factor

Specify typical or actual antenna factor in decibels per metre.

Both gain and antenna factor should be measured using the calibration procedure in A.2.3.1.

A.2.2.3 Directivity and pattern for linearity polarization

Specify antenna pattern and directivity in degrees with a polar plot in both the E and H planes. For less directional antennas, specify the front-to-back ratio in decibels. If omnidirectional, so state.

A.2.2.4 VSWR and impedance

Indicate the maximum VSWR and nominal input impedance in ohms.

A.2.2.5 Active antenna performance

For antennas with active amplified gain, specify the intermodulation product levels, its electric and magnetic field strength immunity level from outside disturbances, and any appropriate check to determine overload or improper operation.

A.2.2.6 Power handling

For immunity use specified maximum and transient power handling capability in watts.

A.2.2.7 Other conditions

Specify the temperature and humidity range in which the antenna must operate and any precautions if used in an unprotected area exposed to the weather.

A.2.3 Antenna calibration

A.2.3.1 Method of calibration for emission measurements

Identify the method used for calibration, i.e.:

- a) calculated (indicate formula used);
- b) measured (specify the method or standard used or the traceability to national calibration laboratory, and whether antennas are calibrated individually).

NOTE For immunity measurements, field strength calibrations are generally made using a secondary calibrated antenna located at the place of the appliance being subjected to the radiation. Hence, no calibrations are required on the transmit antenna.

A.2.3.2 Frequency interval

Indicate the frequencies in megahertz or kilohertz used during the calibration process; if a swept frequency procedure is used, so state.

A.2.3.3 Accuracy of calibration

Specify the nominal accuracy of the calibration in \pm decibels. Indicate the worst case accuracy and the portion of the frequency band where that occurs.

A.2.3.4 Correlation with preferred or specified antennas

If the antenna is to be substituted for a preferred or specified antenna cited in a CISPR publication, indicate all correlation factors in decibels to equate the broadband antenna results to those of the preferred or specified antenna. Also indicate any conversion factor used to convert from the magnetic field intensity or vice versa or for any other conversion to a measurement unit other than a field strength quantity.

A.2.3.5 Units

Specify calibration in units that are necessary to make magnetic or electric field strength emission measurements.

A.2.4 Antenna user information

A.2.4.1 Antenna use

Provide a description of the use of the antenna. Ensure that any special precautions or limitations are cited to reduce the chance of misuse.

A.2.4.2 Physical limitations

Indicate if there are any physical limitations in using the antenna such as the following:

- a) minimum height above the ground plane;
- b) preferred polarization with respect to the ground plane;

- c) special use, i.e. use as a receive antenna or a transmit antenna only. Normally, this is limited to the power handling capability of the balun for passive antennas or the non-bidirectional characteristics for active antennas;
- d) simple ohmic check to determine continuity integrity of antenna;
- e) minimum separation of the closest antenna element to the appliance being measured.

Annex B (normative)

Monopole (1 m rod antenna) performance equations and characterization of the associated antenna matching network ²⁾

B.1 Description

B.1.1 Introduction of the monopole (1 m rod) antenna system

Monopole (rod) antennas are typically used at frequencies below 30 MHz but are sometimes used at higher frequencies. Because of the long wavelength associated with the low frequency range, methods used to calibrate or characterize antennas at higher frequencies are not applicable. The techniques defined in this annex are applicable for frequencies up to 30 MHz. Using due care, this method has been used commercially with small (less than 1 dB) error.

The primary method for traceability of antenna factor to national standards is to illuminate the whole antenna by a plane wave. An alternative method, capacitor substitution of the monopole element, is contained in this annex. Although it is possible to determine the antenna factor by the capacitor substitution method, it requires expert knowledge to achieve the true antenna factor to within ± 1 dB during the actual calibration process. This is especially the case when designing jigs for types of antenna whose monopole element is not attachable by a coaxial connector. Finally, care in the use of the capacitor substitution method is required especially at frequencies above 10 MHz and for active antennas.

B.1.2 Monopole (rod) antenna performance equations

The following equations are used to determine the effective height, self-capacitance and height correction factor of rod or monopole antennas of unusual dimensions.

They are valid only for cylindrical rod antennas shorter than $\lambda/8$ [8] ³⁾.

$$h_e = \frac{\lambda}{2\pi} \tan \frac{\pi h}{\lambda} \quad [1], [2], [3] \quad (\text{B.1})$$

$$C_a = \frac{55,6h}{\left(\ln \frac{h}{a}\right) - 1} \frac{\tan \frac{2\pi h}{\lambda}}{\frac{2\pi h}{\lambda}} \quad [3], [4], [5], [6], [7], [8] \quad (\text{B.2})$$

$$C_h = 20 \log h_e \quad (\text{B.3})$$

where

h_e is the effective height of the antenna, in metres;

h is the actual height of the rod element, in metres;

λ is the wavelength, in metres;

C_a is the self-capacitance of the rod antenna, in picofarads;

²⁾ This annex is based on IEEE 291-1991 (see clause B.5).

³⁾ Figures in square brackets refer to the reference documents cited in clause B.5.

a is the radius of the rod element, in metres;
 C_h is the height correction factor, in dB(m).

B.2 Matching network characterization method

The equivalent capacitance substitution method uses a dummy antenna in place of the actual rod element. The primary component of the dummy antenna is a capacitor equal to the self-capacitance of the rod or monopole. This dummy antenna is fed by a signal source and the output from the matching network or base unit of the antenna is measured using the test configuration shown in figure B.1. The antenna factor (AF) in dB(1/m) is given by equation (B.4).

$$AF = V_D - V_L - C_h \quad (\text{B.4})$$

where

V_D is the measured output of the signal generator, in dB(μ V);
 V_L is the measured output of the matching network, in dB(μ V);
 C_h is the height correction factor (for the effective height), in dB(m).

For the monopole (1 m rod) antenna commonly used in EMC measurements, the effective height (h_e) is 0,5 m, the height correction factor (C_h) is -6 dB(m) and the self-capacitance (C_a) is 10 pF.

NOTE See B.1.2 to calculate the effective height, height correction factor and self-capacitance of rod antennas of unusual dimensions.

Either of two procedures shall be used: the method of B.2.1, the network analyser, or the method of B.2.2, the signal generator and radio-noise meter method. The same dummy antenna is used in both procedures. See clause B.3 for guidance in making a dummy antenna. Measurements shall be made at a sufficient number of frequencies to obtain a smooth curve of antenna factor versus frequency over the operating range of the antenna, or 9 kHz to 30 MHz, whichever is smaller.

B.2.1 Network analyser procedure

- a) Calibrate the network analyser with the cables to be used in the measurements.
- b) Set up the matching network to be characterized and the measuring equipment as shown in figure B.1.
- c) Subtract the signal level (in dB(μ V)) in the test channel from the signal level (in dB(μ V)) in the reference channel and subtract C_h (-6 dB for the 1 m rod) to obtain the antenna factor (in dB(1/m)) of the antenna.

NOTE Attenuator pads are not needed with the network analyser because the impedances of the channels in the network analyser are very nearly 50 Ω and any errors are corrected during network analyser calibration. Attenuator pads may be used, if desired, but including them complicates the network analyser calibration.

B.2.2 Radio-noise meter and signal generator procedure

- a) Set up the matching network to be characterized and the measuring equipment as shown in figure B.2.
- b) With the equipment connected as shown and a 50 Ω termination on the T-connector (A), measure the received signal voltage V_L (in dB(μ V)) at the RF port (B).

- c) Leaving the RF output of the signal generator unchanged, transfer the 50 Ω termination to the RF port (B) and transfer the receiver input cable to the T-connector (A). Measure the drive signal voltage V_D (in dB(μV)).
- d) Subtract V_L from V_D and subtract C_h (-6 dB for the 1 m rod) to obtain the antenna factor (in dB(1/m)) of the antenna.

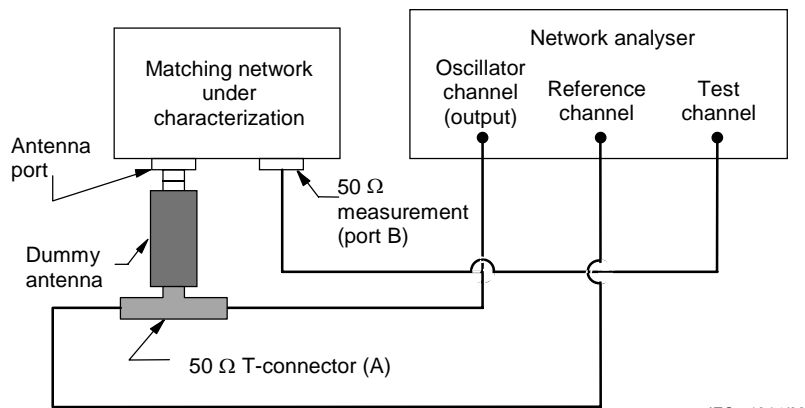

IEC 1914/02

NOTE 1 Place the dummy antenna as close to the EUT port as possible. Place the T-connector as close to the dummy antenna as possible. Use the same length and type of cables between the T-connector and the reference channel input, and the T-connector and the 50 Ω measuring port test channel.

NOTE 2 Attenuator pads are not needed with the network analyser and are not recommended.

Figure B.1 – Method using network analyser

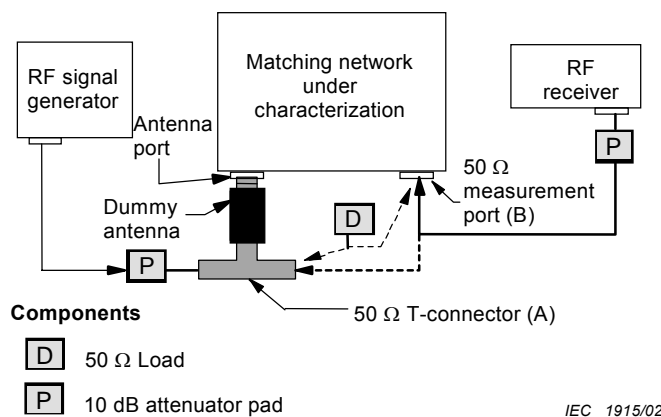

IEC 1915/02

NOTE 1 Place the dummy antenna as close to the EUT port as possible. Place the T-connector as close to the dummy antenna as possible.

NOTE 2 If the VSWR of receiver and signal generator is low, pads may not be needed or may be reduced to 6 dB or 3 dB.

NOTE 3 The dummy antenna may incorporate other matching components to control VSWR at its input and signal generator level at measuring ports.

Figure B.2 – Method using radio-noise meter and signal generator

The 50 Ω termination shall have a very low standing-wave ratio (SWR) (less than 1,05:1). The radio-noise meter shall be calibrated and have a low SWR (less than 2:1). The output of the signal generator shall be frequency and amplitude stable.

NOTE The signal generator need not be calibrated, since it is used as a transfer standard.

B.3 Dummy antenna considerations

The capacitor used as the dummy antenna shall be mounted in a small metal box or on a small metal frame. The leads shall be kept as short as possible, but no longer than 8 mm, and spaced 5 mm to 10 mm from the surface of the metal box or frame. See figure B.3.

The T-connector used in the antenna factor measurement set-up may be built into the dummy antenna box. The resistor pad to provide impedance matching to the generator may also be built into the dummy antenna box.

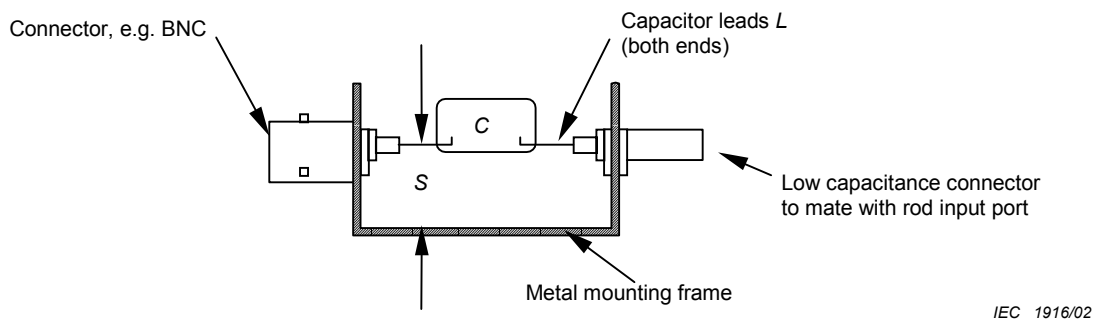

IEC 1916/02

Components

- C antenna capacitance (C_a) calculated from equation (B.2), 5 % tolerance, silver mica.
- S lead spacing, 5 mm to 10 mm (10 mm from all surfaces if enclosed in a box).
- L lead length, as short as possible but not greater than 8 mm (total lead length not greater than 40 mm, including both capacitor leads and length of rod port connector).

Figure B.3 – Example of mounting capacitor in dummy antenna

B.4 Application of the monopole (rod) antenna

A monopole rod antenna is typically designed to be used with a counterpoise or to be mounted on a groundplane. To obtain correct field strength values, the manufacturer's instructions or recommendations regarding the use of the counterpoise or groundplane should be followed.

If the antenna uses a telescoping rod element, the element shall be extended to the length specified in the manufacturer's instruction.

Many measurement standards specify that the counterpoise of a monopole (rod) antenna shall be bonded to the groundplane or test bench groundplane. The requirements of the measurement standard shall be met.

B.5 Reference documents

- [1] IEEE 291-1991, *IEEE Standard Methods for Measuring Electromagnetic Field Strength of Sinusoidal Continuous Waves, 30 Hz to 30 GHz*. IEEE, Inc., 445 Hoes Lane, PO Box 1331, Piscataway, NJ 08855-1331 USA, p. 28-29.
- [2] GREENE, FM. NBS Field-Strength Standards and Measurements (30 Hz to 1000 MHz). *Proc. IEEE*, No. 6, June 1967, vol. 55, p. 974-981.
- [3] SCHELKUNOFF, SA. and FRIIS, HT. *Antennas: Theory and Practice*. New York: John Wiley and Sons, Inc., 1952, p. 302-331.
- [4] SCHELKUNOFF, SA. Theory of Antennas of Arbitrary Size and Shape. *Proc of the IRE*, Sept. 1941, vol. 29, p. 493-592.
- [5] WOLFF, EA. *Antenna Analysis*. New York: John Wiley and Sons, Inc., 1966, p. 61.
- [6] HALLÉN, E. Theoretical Investigation into the Transmitting and Receiving Qualities of Antennas. *Nova Acta Soc. Sci. Upsaliensis*, Ser. IV, 11, No. 4, 1938, p. 1-44.
- [7] KING, RWP., *Theory of Linear Antennas*, Harvard University Press, Cambridge, MA, 1956, p.16-17, 71, 184 and 487.
- [8] *The Radio Frequency Interference Meter NAVSHIPS 94810*, by The Staff of the Moore School of Electrical Engineering, University of Pennsylvania, 1962, p. 36-38.

Annex C (normative)

Loop antenna system for magnetic field induced current measurements in the frequency range of 9 kHz to 30 MHz

C.1 Introduction

This annex sets forth information and data concerning the loop antenna system (LAS) to measure the current induced in the LAS by the magnetic field emitted by a single EUT, positioned in the centre of the LAS, in the frequency range of 9 kHz to 30 MHz. Subclause 4.7 of this publication and CISPR 16-2-3 refer to this LAS.

A description of the LAS is given, as well as the method of validation of the antennas of the LAS. Conversion factors are given to relate magnetic field induced current data to magnetic field data which would have been obtained when the same EUT was measured using a single-loop magnetic field antenna positioned at a specified distance from that EUT.

C.2 Construction of the loop antenna system (LAS)

The LAS, figure C.1, consists of three mutually perpendicular large-loop antennas (LLAs), described in clause C.3. The entire LAS is supported by a non-metallic base.

A 50 Ω coaxial cable between the current probe of an LLA and the coaxial switch, and between this switch and the measuring equipment, shall have a surface transfer impedance smaller than 10 m Ω /m at 100 kHz and 1 m Ω /m at 10 MHz. This requirement is met when using, for example, double-braided shield RG 223/U coaxial cable.

All connectors shall have a surface transfer impedance comparable with that of the coaxial cable. This requirement is met, for example, when using good quality BNC collet-lock type connectors (see IEC 60169-8*).

All cables shall be equipped with ferrite absorbers, F in figure C.1, providing a common-mode series resistance of $R_s > 100 \Omega$ at 10 MHz. This requirement is met when constructing the ferrite toroid from, for example, 12 rings of type 3E1 from Ferroxcube (minimum size in millimetres: 29 O.D. \times 19 I.D. \times 7,5 Ht).

C.3 Construction of a large-loop antenna (LLA)

A large-loop antenna (LLA) of the LAS is constructed from coaxial cable of which the surface transfer impedance has been specified in clause C.2. In addition, the resistance of the inner conductor of the LLA shall be sufficiently low (see note 1). Both requirements are met, for example, when using double-braided shield RG 223/U coaxial cable.

* IEC 60169-8:1978, *Radio-frequency connectors – Part 8: RF coaxial connectors with inner diameter of outer conductor 6,5 mm (0,256 in) with bayonet lock – Characteristic impedance 50 ohms (Type BNC)*.

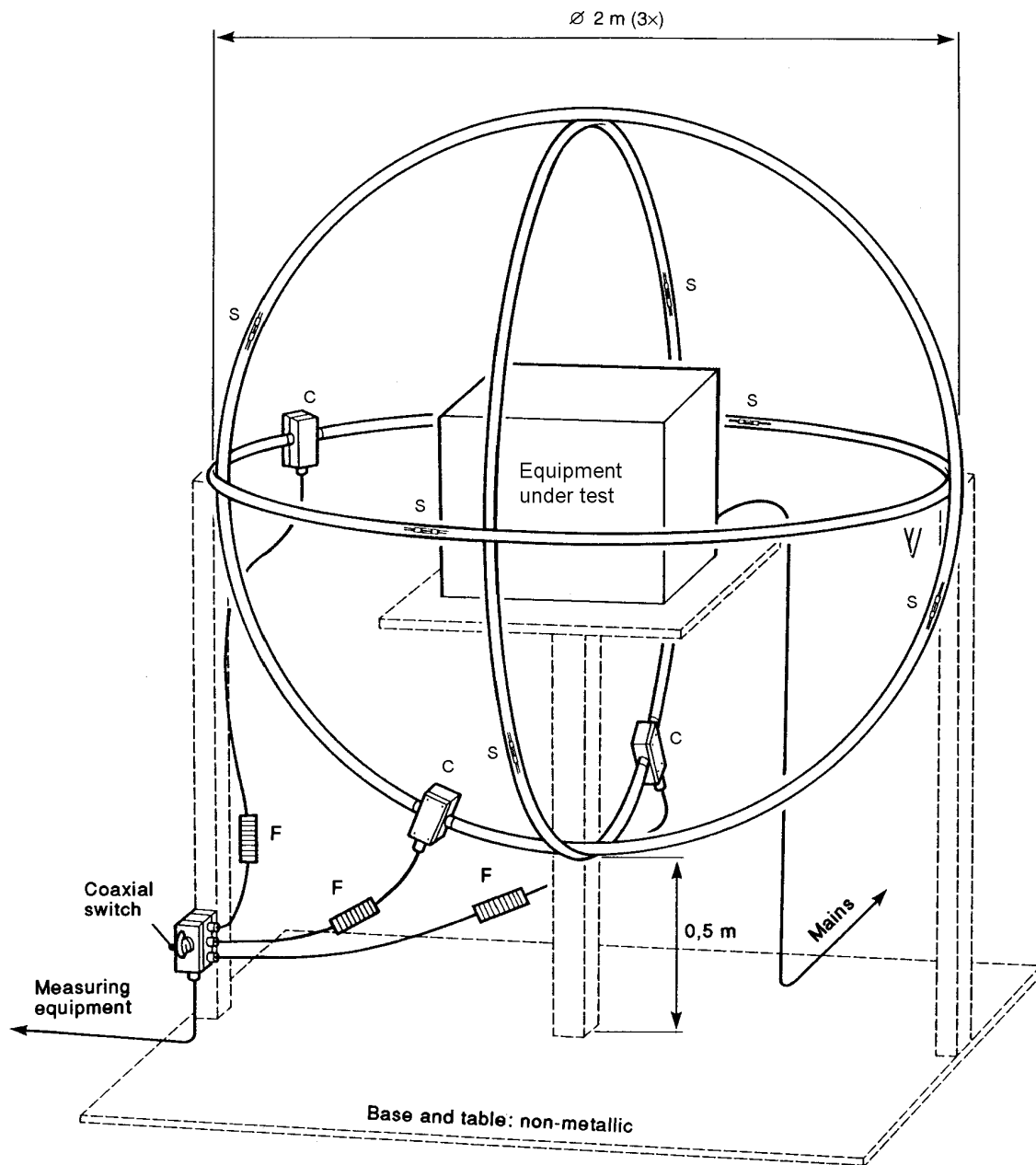

IEC 1 004/97

- S = antenna slit
- C = current probe
- F = ferrite absorber

Figure C.1 – The loop-antenna system, consisting of three mutually perpendicular large-loop antennas

To keep the loop in its circular shape and to protect the slit construction, as in the example of figure C.2, the cable is inserted in a thin walled non-metallic tube with inner diameter of approximately 25 mm. Other non-metallic constructions serving the same purposes may be used.

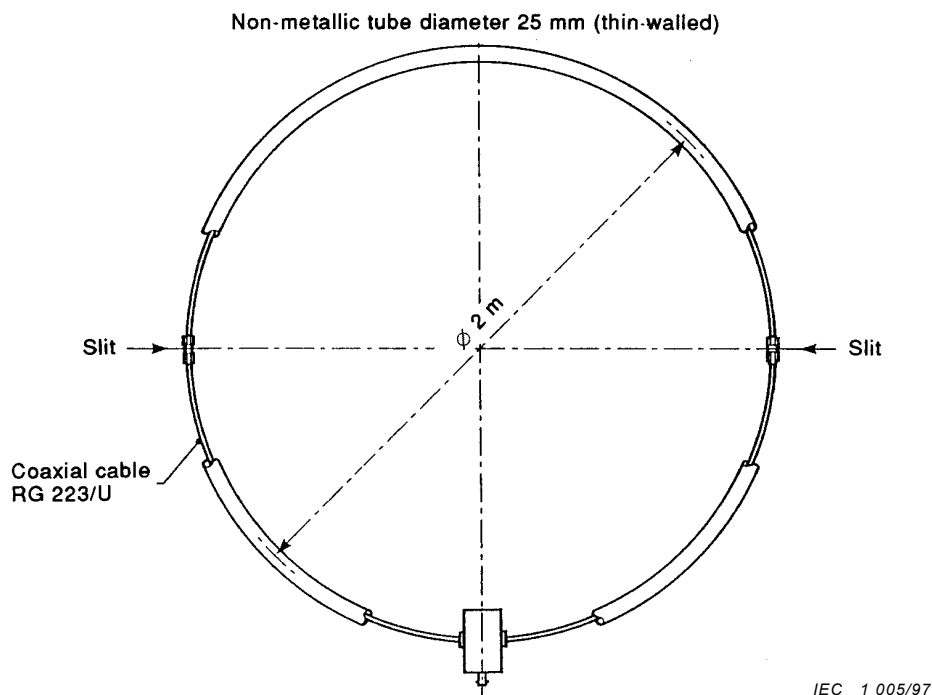
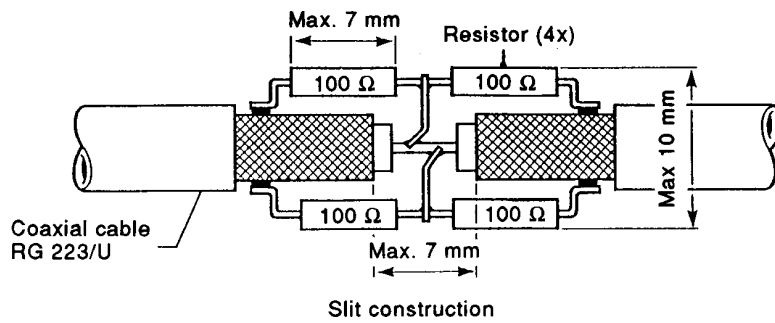

Figure C.2 – A large-loop antenna containing two opposite slits, positioned symmetrically with respect to the current probe C

The loop diameter has been standardized to be $D = 2$ m. If necessary, e.g. the case of large EUT, D may be increased. However, in the frequency range up to 30 MHz the maximum allowable diameter is 4 m. Further increase of the diameter would result in non-reproducible resonances of the LAS response at the high-frequency end of the measuring range.

It should be noted that by increasing the diameter, its sensitivity to ambient noise increases proportionally to the diameter, and its sensitivity to wanted signals is inversely proportional with the diameter squared.

An LLA contains two opposite slits, positioned symmetrically with respect to the current probe of the LLA (see figure C.2). Such a slit, made in the outer conductor of the coaxial antenna cable as shown in figure C.3, shall have a width of less than 7 mm. The slit is bridged by two parallel sets of 100 Ω resistors in series. The centre of each series circuit is connected to the inner conductor of the coaxial antenna cable.



IEC 1 006/97

Figure C.3 – Construction of the antenna slit

At each side of the slit the outer conductor of the coaxial antenna cable may be bonded to a strap of printed circuit board material with two copper rectangles, separated by at least 5 mm, in order to obtain a rigid slit construction (see figure C.4).

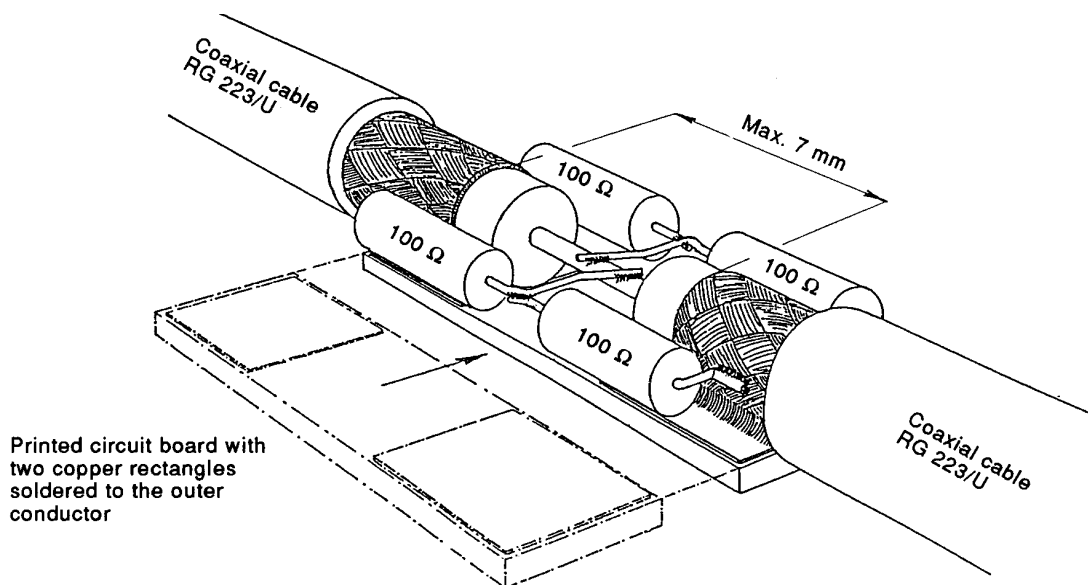

IEC 1 007/97

Figure C.4 – Example of antenna-slit construction using a strap of printed circuit board to obtain a rigid construction

The current probe around the inner conductor of the coaxial antenna-cable shall have a sensitivity of 1 V/A over the frequency range of 9 kHz to 30 MHz. The insertion loss of the current probe shall be sufficiently low (see note 1).

The outer conductor of that cable shall be bonded to the metal box containing the current probe (see figure C.5). The maximum dimensions of this box are the following: width 80 mm, length 120 mm and height 80 mm.

NOTE 1 To obtain a flat frequency response of the LLA at the lower end of the frequency range of 9 kHz to 30 MHz, the insertion loss R_c , of the current probe should be much smaller than $2 \pi f L_c$ at $f = 9$ kHz, where L_c represents the inductance of the current probe. In addition, $(R_c + R_i) \ll X_i = 2 \pi f L$ at 9 kHz, where R_i is the resistance of the inner conductor of the loop and L is the loop inductance. This inductance is about $1,5 \mu\text{H/m}$ of circumference, Hence for the standardized LLA, $X_i \approx 0,5 \Omega$ at $f = 9$ kHz.

NOTE 2 To avoid unwanted capacitive coupling between the EUT and the LAS, the distance between the EUT and components of the LLA shall be at least 0,10 times the loop diameter. Particular attention must be paid to the leads of an EUT. Cables should be routed together and leave the loop volume in the same octant of the cell, no closer than 0,4 m to any of the LAS loops (see figure C.6).

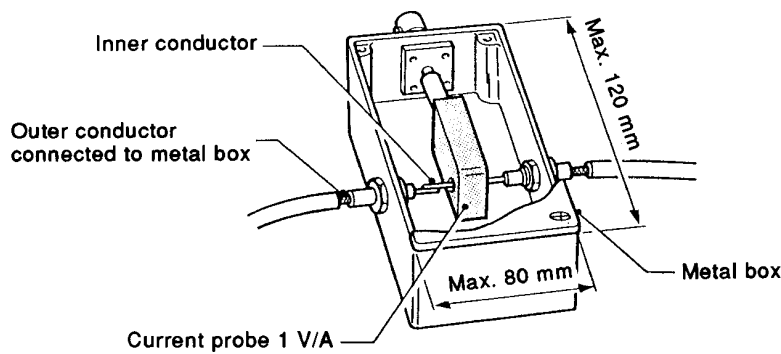

IEC 1 008/97

Figure C.5 – Construction for the metal box containing the current probe

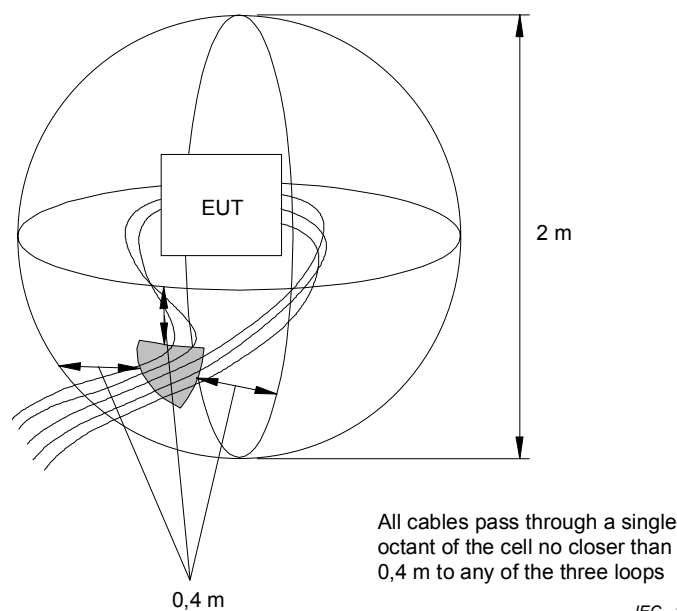

IEC 1 009/97

Figure C.6 – Example showing the routing of several cables from an EUT to ensure that there is no capacitive coupling from the leads to the loop

C.4 Validation of a large-loop antenna (LLA)

The validation and calibration of a large-loop antenna (LLA) of the loop antenna system is carried out by measuring the current induced in the LLA by the balun-dipole connected to a 50Ω RF generator, described in clause C.5. The magnetic field emitted by that dipole allows verification of the magnetic field sensitivity of the LLA. The electric field emitted by the balun-dipole shows that the electric field sensitivity of the LLA is sufficiently low.

The induced current shall be measured as a function of frequency in the range of 9 kHz to 30 MHz at the 8 positions of the balun-dipole in figure C.7. During this measurement the balun dipole is in the plane of the LLA under test.

In each of the eight positions, the validation factor [expressed in $\text{dB}(\Omega) = 20 \log(V_{g0}/I_1)$] of the open circuit voltage of the RF generator (V_{g0}) and the measured current (I_1) shall not deviate more than ± 2 dB from the validation factor given in Figure C.8.

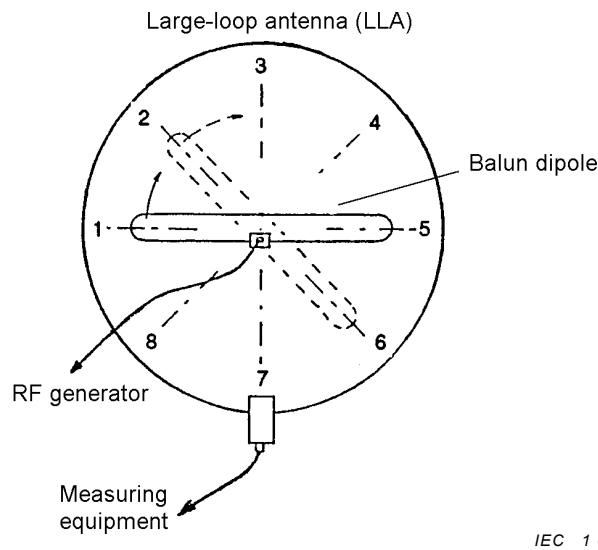

Figure C.7 – The eight positions of the balun-dipole during validation of the large-loop antenna

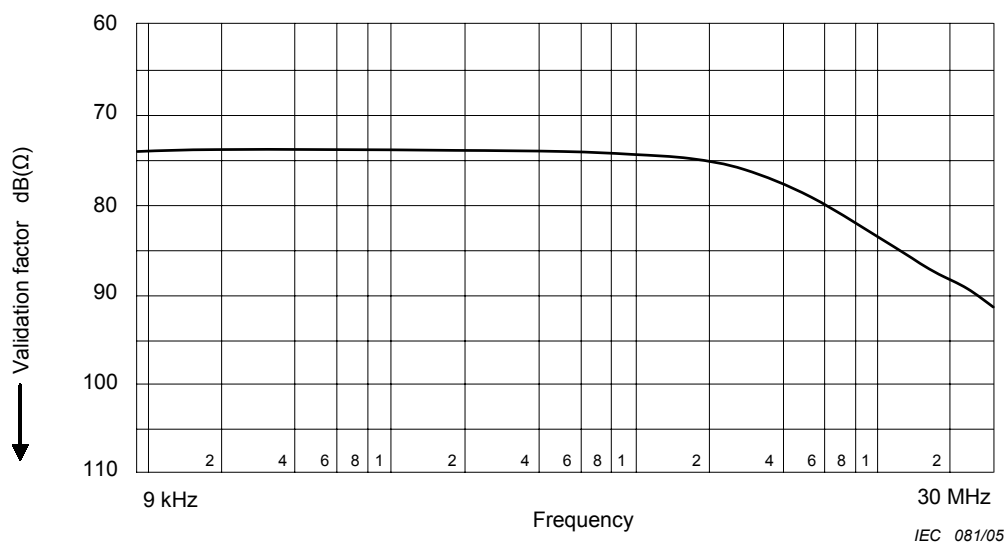

Figure C.8 – The validation factor for a large loop-antenna of 2 m diameter

The validation factor given in figure C.8 is valid for a circular LLA with a standardized diameter $D = 2$ m. If the diameter of a circular LLA differs from $D = 2$ m, the validation factor for the non-standardized LLA can be derived from the data given in figures C.8 and C.11 (clause C.6).

C.5 Construction of the balun-dipole

The balun-dipole, figure C.9, has been designed to emit simultaneously a magnetic field, which should be measured by the LLA, and an electric field, which should be rejected by the LLA.

The balun-dipole is constructed from RG 223/U coaxial cable. It has a width $W = 150$ cm and a height $H = 10$ cm (cable centre to cable centre distances), as depicted in figure C.9.

A slit in the outer conductor of the coaxial cable divides the dipole in two halves. One half of this dipole, the right-hand half in figure C.9, is short-circuited near the slit as well as near the connector. Short-circuited means that the inner and outer conductors of the coaxial cable are electrically bonded together. This half is connected to the reference-ground of the BNC connector. The inner conductor of the coaxial cable, forming the left-hand half of the dipole in figure C.9, is connected to the centre-pin of the BNC connector and its outer conductor to the reference ground of that BNC connector.

A small metal box is used to screen the connections near the dipole connector. The outer conductor of the two halves of the coaxial dipole cable are bonded to this box, as is the reference ground of the BNC connector.

To obtain a rigid construction the dipole is supported by a non-conductive base.

C.6 Conversion factors

This clause deals with the factor which converts the current (I) induced in the LLA by the EUT into a magnetic field strength H at a specified distance from the EUT (see figure C.10). It also deals with the factor which converts the current measured in an LLA with a non-standardized diameter to a current which would have been measured using an LLA with the standardized diameter of $D = 2$ m (see figure C.11).

The conversion factor in figure C.10 applies to a source of magnetic field positioned in the centre of the LLA with its dipole moment perpendicular to the plane of that LLA. It should be noted that with the loop antennas specified in 4.2, the loop antenna is always positioned in a vertical plane and the EUT is only rotated around its vertical axis. Hence, in that case only the horizontal dipole moments, i.e. the dipole moments parallel to the ground plane, are measured. Consequently, in the case of a vertical dipole moment the conversion factor cannot be used to compare results of both measuring methods. However, the factor can be used when in the magnetic field measuring method the loop antenna would be positioned in a horizontal plane, or when in that method the EUT would be tilted through 90° , so that the relevant vertical dipole moment is changed into a horizontal one.

If the actual position of a disturbance source inside an EUT is at a distance less than 0,5 m from the centre of the standardized LAS, the measuring results differ by less than 3 dB from those with that source in the centre.

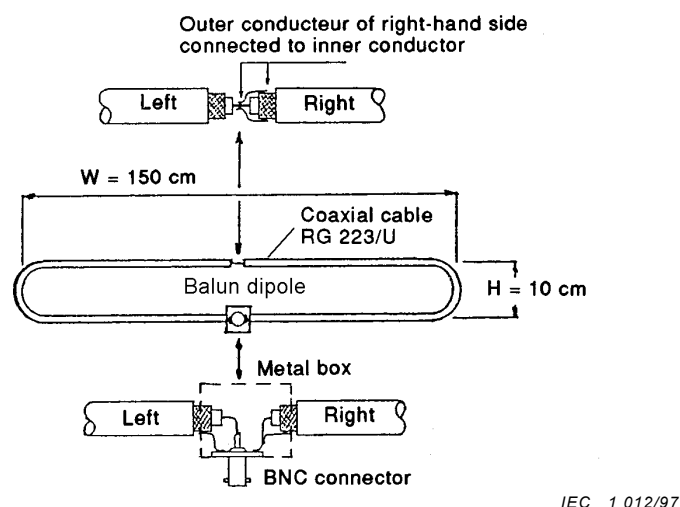

Figure C.9 – Construction of the balun-dipole

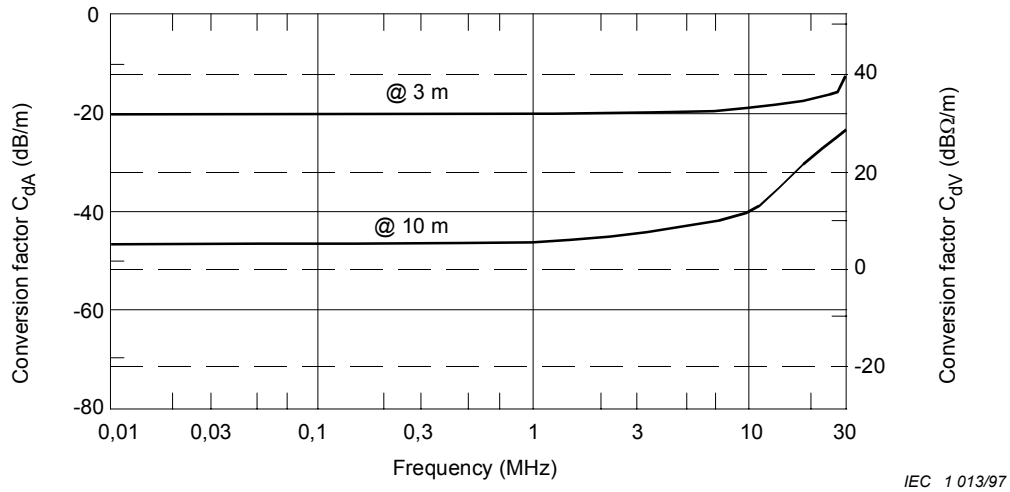

Figure C.10 – Conversion factors C_{dA} (for conversion into dB (μ A/m)) and C_{dV} (for conversion into dB (μ V/m)) for two standardized measuring distances d

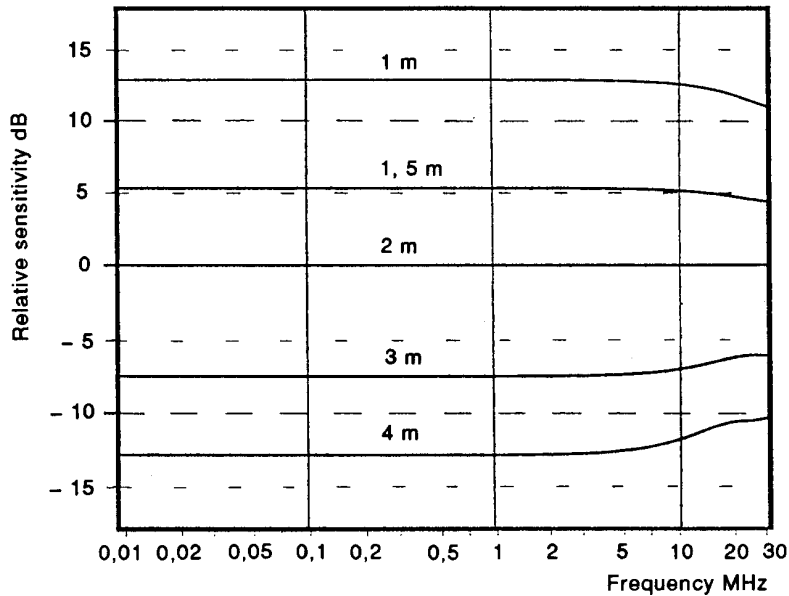

Figure C.11 – Sensitivity S_D of a large-loop antenna with diameter D relative to a large-loop antenna having a diameter of 2 m

The relation between the magnetic field strength H in dB(μ A/m) measured at a distance d and the current I in dB(μ A) is:

$$H [\text{dB}(\mu\text{A/m})] = I [\text{dB}(\mu\text{A})] + C_{dA} (\text{dBm}^{-1})$$

where C_{dA} is the current-to-field conversion factor for a certain distance d when expressing H in dB(μ A/m) see also the note after the following equation.

In general, the conversion factor is frequency-dependent; figure C.10 presents C_{dA} for standardized distances of 3 m and 10 m. For the standardized distance $d = 30$ m the conversion factor is under consideration.

The ratio S_D in decibels, of the current measured in a LLA with a diameter D , in metres, and the current which would have been measured with an LLA having the standardized diameter $D = 2$ m, are given in figure C.11 for several values of D . Using this ratio, the equation given above can be written as:

$$H [\text{dB}(\mu\text{A}/\text{m})] = I [\text{dB}(\mu\text{A})] - S_D(\text{dB}) + C_{dA} (\text{dBm}^{-1})$$

NOTE For disturbance calculations, CISPR uses the magnetic field strength H in $\text{dB}(\mu\text{A}/\text{m})$ instead of $\text{dB}(\mu\text{V}/\text{m})$. In this context, the relation between H expressed in $\text{dB}(\mu\text{A}/\text{m})$ and H expressed in $\text{dB}(\mu\text{V}/\text{m})$ is given by:

$$H [\text{dB}(\mu\text{V}/\text{m})] = H [\text{dB}(\mu\text{A}/\text{m})] + 51,5 [\text{dB}(\Omega)]$$

For convenience the conversion factor C_{dV} converting $I [\text{dB}(\mu\text{A})]$ into $H [\text{dB}(\mu\text{V}/\text{m})]$ is also given in figure C.10.

The following examples explain the use of the three equations above and of figures C.10 and C.11.

- a) Given: measuring frequency $f = 100$ kHz, loop diameter $D = 2$ m, current in loop $I = X$ $\text{dB}(\mu\text{A})$.

Then using the first equation and figure C.10, it follows that:

$$\text{at } d = 3 \text{ m: } H [\text{dB}(\mu\text{A}/\text{m})] = X [\text{dB}(\mu\text{A})] + C_{3A} (\text{dBm}^{-1}) = (X - 19,5) \text{ dB}(\mu\text{A}/\text{m})$$

$$\text{at } d = 3 \text{ m: } H [\text{dB}(\mu\text{V}/\text{m})] = X [\text{dB}(\mu\text{A})] + C_{3V} [\text{dB}(\Omega/\text{m})] = [X + (51,5 - 19,5)] \text{ dB}(\mu\text{V}/\text{m})$$

- b) Given: measuring frequency $f = 100$ kHz, loop diameter $D = 4$ m, current in loop $I = X$ $\text{dB}(\mu\text{A})$.

Then using figure C.11 it follows that the same EUT would have induced a current:

$$I [\text{dB}(\mu\text{A})] = X - S_3 (\text{dB}) = (X + 13) \text{ dB}(\mu\text{A})$$

in the LLA with the standard diameter $D = 2$ m.

- c) Given: validate an LLA with diameter $D = 3$ m.

Then the validation factor is found by subtracting, at each frequency, S_3 , the value of the relative sensitivity as given in Figure C.11, from the validation factor as given in Figure C.8. Hence, if the measuring frequency is 100 kHz, the validation factor for the LLA with $D = 3$ m equals $(73,5 - (-7,5)) = 81$ $\text{dB}(\Omega)$.

C.7 Reference document

A Large-Loop Antenna for Magnetic Field Measurements, J.R. Bergervoet and H. Van Veen, Proceedings of the 8th International Zürich Symposium on EMC, pp 29-34, March 1989, ETH Zentrum - IKT, 8092 Zürich, Switzerland.

Annex D (informative)

Construction details for open area test sites in the frequency range of 30 MHz to 1 000 MHz (clause 5)

D.1 General

Subclauses 5.1 through 5.5 contain major construction considerations for open area test sites. Additional details that are helpful in assuring a well constructed site and all weather enclosure are described in this annex. A positive way to assure the suitability of these practices is to perform NSA measurements as described in 5.6.

D.2 Ground plane construction

D.2.1 Material

Metal is the recommended ground plane material for field strength test sites. However, for practical reasons, metallic ground planes cannot be specified for measurement of all equipment. Some examples of metallic ground planes include solid metal sheets, metal foil, perforated metal, expanded metal, wire cloth, wire screen and metal grating. The ground plane should have no voids or gaps with linear dimensions that are an appreciable fraction of a wavelength at the highest measurement frequency. The recommended maximum opening size for screen, perforated metal, grating or expanded metal type ground planes is 1/10 of a wavelength at the highest frequency of measurement (about 3 cm at 1 000 MHz). Material comprised of individual sheets, rolls, or pieces should be soldered or welded at the seams preferably continuously but in no case with gaps longer than 1/10 wavelength. Thick dielectric coatings, such as sand, asphalt, or wood on top of metal ground planes may result in unacceptable site attenuation characteristics.

D.2.2 Roughness

The Rayleigh roughness criterion provides a useful estimate of maximum allowable r.m.s. ground plane roughness (see figure D.1). For most practical test sites, especially for 3 m separation applications, up to 4,5 cm of roughness is insignificant for measurement purposes. Even more roughness is allowed for 10 m and 30 m sites. The site validation procedure in 5.6 shall be performed to determine whether the roughness is acceptable.

D.3 Services to EUT

Electrical service or mains wiring to the EUT should be run under the ground plane to the maximum extent possible and preferably at right angles to the measurement axis. All wires, cables, and plumbing to the turntable or mounting of the EUT should also be run under the ground plane. When underground routing is not possible, service to the EUT should be placed on top of, but flush with, and bonded to the ground plane.

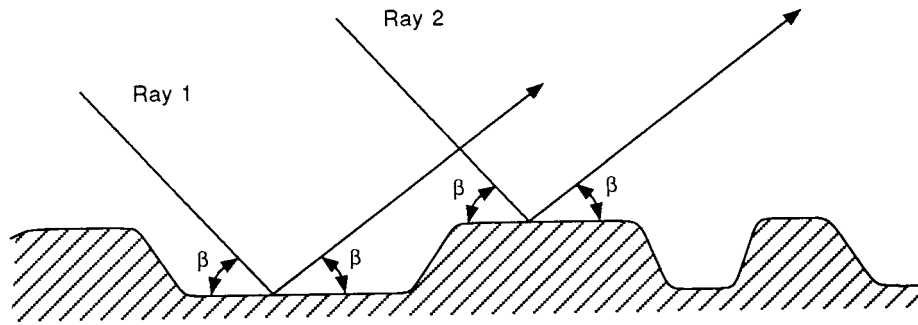

IEC 1329/99

Figure D.1 – The Rayleigh criterion for roughness in the ground plane

Measurement distance <i>R</i> m	Source height, <i>h</i> ₁ m	Maximum receiving antenna height, <i>h</i> ₂ m	Maximum RMS roughness	
			<i>b</i>	
			In wavelengths	At 1 000 MHz cm
3	1	4	0,15	4,5
10	1	4	0,28	8,4
30	2	6	0,49	14,7

The values of *b* are calculated according to the formula:

$$b = \frac{\lambda}{8 \sin \beta}$$

D.4 Weather protection enclosure construction

D.4.1 Materials and fasteners

Up to 1 000 MHz, thin sections of fibreglass and most other plastics, specially treated woods, and fabric material will not cause appreciable attenuation of EUT emissions. Moisture absorption in some materials (e.g., wood and nylon), however, can cause transmission losses which are particularly critical if EUT emissions are measured through such material. Care should be taken to ensure that air-deposited conductive particles and standing water and ice do not build up on the structure or within the material forming the structure. Inspections should be made periodically for foreign objects which might lodge on the structure causing measurement errors.

Use of metal above the ground plane should be kept to a minimum. Use of plastic or fabric fasteners is highly recommended. Any anchors, pilings, or similar foundations should be far enough removed from the test area so as not to affect the measurement.

D.4.2 Internal arrangements

All structural members should be non-reflective. Any blowers or ducts for heating, cooling or air support should be outside the test area or outside the structure, unless they are made of non-conductive material or run below a metallic ground plane or well below a non-metallic ground plane. Temperature and humidity control may be required for the operation of the equipment. Any insulation or windows should be free of metal backing or framing. Any safety rails or stairs should also be non-conductive if located above the ground plane.

D.4.3 Size

The size of a weather protection enclosure will depend upon the size of the EUT and whether or not the entire antenna range is to be enclosed or only the area over the EUT, the area over the measuring set, or the area enclosing the receive antenna positioner and the highest extent of the receiving antenna when making vertical polarization measurements.

D.4.4 Uniformity with time and weather

It is recommended that periodic normalized site attenuation measurements be made in order to detect anomalies caused by degradation of the all-weather protection due to weather conditions (e.g. moisture absorption) or contamination of enclosure materials. This measurement also checks the calibration of RF cabling and test instrumentation. A six-month interval is generally adequate unless physical signs indicate material degradation sooner, i.e. material changes colour due to air-borne contaminants.

D.5 Turntable

A turntable is recommended for convenience in measuring electromagnetic emissions from all sides of the EUT. For testing a floor-standing EUT, the turntable should be metal-covered, flush with the ground plane and conductively connected to it. A non-metallic turntable above the ground plane surface or combination of metallic turntable and non-metallic table sitting on top of the turntable may be used for testing a table-top EUT. A slightly raised, non-metallic turntable may also be acceptable for testing floor-standing EUT.

D.6 Receiving antenna mast installation

The receiving antenna should be mounted on a non-conducting support which will allow the antenna to be raised between 1 m and 4 m for measurement distances of 10 m and less, and between 1 m and 4 m, or between 2 m and 6 m for distances greater than 10 m. The cable shall be connected to the antenna balun such that for horizontally polarized antennas the cable is orthogonal to the axis of the antenna elements at all antenna heights in order to maintain balance with respect to ground. The cabling from the receiving antenna balun should drop vertically to the ground plane approximately 1 m or more to the rear of the receiving antenna. From that point it should be kept on or under the ground plane in a manner so as not to disturb the measurement. The cable between the antenna and disturbance analyzer should be as short as practical to ensure acceptable received signal levels at 1 000 MHz.

For vertically polarized dipole-type antennas, the cabling to the measuring receiver should be maintained horizontal, i.e., parallel to the ground plane, for a distance of approximately 1 m or more to the rear of the receiving antenna (away from the EUT) before dropping to the ground plane. An antenna boom approximately 1 m in length will suffice. The remaining cable routing to the analyzer is the same as for the horizontally-polarized case.

For both cases, the antenna factor calibration should not be affected by the presence of the antenna positioners and disposition of the coaxial cabling attached to the antenna.

Annex E (normative)

Validation procedure of the open area test site for the frequency range of 30 MHz to 1 000 MHz (clause 5)

E.1 General

Subclause 5.6 contains the general requirements and procedures for determining site validation using normalized site attenuation measurements. This annex provides step-by-step procedures to perform the NSA measurements.

E.2 Discrete frequency method

E.2.1 Measurement set-up

Refer to figures 4 and 5 for specific test set-up details. The signal generator is connected to the transmit antenna with an appropriate length of transmission line. The transmit antenna is placed in the desired location. The transmit antenna height is set to h_1 (see tables E.1, E.2 and E.3 for the values of h_1) and the desired polarization is selected. If a tunable dipole is used, the length is adjusted for the required frequency.

The receive antenna is mounted on a mast which allows scanning over the height range h_{2min} to h_{2max} , placed at a distance R from the transmit antenna, and connected to the measuring receiver or spectrum analyzer via a suitable length of cable. The same polarization as that for the transmit antenna is selected and, if a tunable dipole is used, the antenna is adjusted to the required frequency. The 25 cm ground clearance is maintained for vertically oriented tuned dipoles (see table E.3).

For all NSA measurements using tunable dipoles, it is assumed that these antennas are tuned to each frequency, including those between 30 MHz and 80 MHz.

E.2.2 Measurement procedure

The following steps should be used for each frequency indicated in tables E.1, E.2, and E.3. The measurements are first made for antennas horizontally aligned and then for antennas vertically aligned with the transmit antenna height set at h_1 .

- 1) Adjust the output level of the signal generator to give a received voltage display well above ambient and measuring receiver or spectrum analyzer noise.
- 2) Raise the receiving antenna on the mast through scan h_2 as indicated in tables E.1, E.2 and E.3, as appropriate.
- 3) Record the maximum signal level. This value is V_{SITE} in equation (1), in 5.6.1.
- 4) Disconnect the transmit and receive cables from their antennas. Directly connect these cables with a straight through adapter.
- 5) Record the signal level with the transmit and receive cables connected. This value is V_{DIRECT} in equation (1), in 5.6.1.

- 6) At each frequency and for each polarization, enter the values in steps 3 and 5 in equation (1), in 5.6.1.
- 7) Insert the transmit and receive antenna factors at the measurement frequency as shown in equation (1).
- 8) Insert the mutual impedance correction factor ΔAF_{TOT} from table E.4 which applies only for the specific geometry of horizontal polarization using tunable dipoles separated by 3 m. $\Delta AF_{TOT} = 0$ for all other geometries.
- 9) Solve equation (1) for A_N which is the NSA for the measurement frequency and polarization used.
- 10) Subtract the value in step 9 from the appropriate NSA contained in tables E.1, E.2 and E.3, as appropriate.
- 11) If the results in step 10 are less than ± 4 dB, the site is considered validated at that frequency and polarization.
- 12) Repeat steps 1 through 11 for the next frequency and polarization combination.

E.3 Swept frequency method

E.3.1 Measurement set-up

The set-up is similar to that contained in E.2.1 except that only broadband antennas are used. No restrictions in vertical polarization antenna movement is necessary due to the physically small size of such broadband antennas.

E.3.2 Measurement procedure

The following steps should be made using automatic measuring equipment having a peak hold (max. hold), storage capability, and tracking generator. In this method, both receive antenna height h_2 and frequency are scanned or swept over the required frequency ranges. The frequency ranges are usually determined by the type of broadband antenna used. The frequency sweep speed shall be much greater than the antenna height scan rate. Set the transmit antenna height to h_1 .

- 1) Adjust the output level of the tracking generator to give a received voltage display well above ambient scanning receiver or spectrum analyzer noise.
- 2) Raise the receiving antenna on the mast to the maximum height of the scan range as indicated in the appropriate table E.1.
- 3) Set the spectrum analyzer to sweep the desired frequency range. Ensure that the spectrum analyzer is adjusted so that a similar signal up to 60 dB higher can be displayed on the same amplitude scale. This will accommodate the levels to be recorded in step 5.
- 4) Slowly lower the receiving antenna to the minimum height of the scan range as indicated in the tables for the appropriate site geometry. Store or record the maximum received voltage display V_R in dB(μ V). (The time it takes to lower the antenna should be much longer than the spectrum analyzer sweep time.)
- 5) Disconnect the transmit and receive cables and connect them directly with a straight through adapter. Store or record the resulting voltage display.
- 6) At each frequency, subtract the voltage measured in step 4 from the voltage measured in step 5. Also subtract the antenna factors of the transmit and receive antennas, AF_T (dB/m) and AF_R (dB/m), respectively. (Antenna factors as a continuous function of frequency can be obtained by using simple linear curve fitting on a set of discrete antenna factor values.) The result is the measured NSA over the range of frequencies used, which should be

plotted. Also plot the theoretical normalized site attenuation for an ideal site shown in table E.1.

- 7) The differences found between the theoretical NSA and the measured NSA shall fall within the ± 4 dB criterion.

NOTE For both NSA measurement methods, an impedance mismatch in the output of the signal source or at the input of the measuring receiver or spectrum analyzer may result in reflections which could cause errors. This should be avoided by use of padding attenuators of 10 dB; one at the output end of each transmitting and receiving antenna cable. These attenuators shall remain in the cables during the entire measurement for NSA.

E.4 Possible causes for exceeding site acceptability limits

If the deviation exceeds the ± 4 dB criterion, investigate as follows:

First check the measurement system calibrations. If the signal generator and measuring instrumentation do not drift during the measurements, the prime suspects are the antenna factors. Antennas may also be defective. If these all check out, repeat the measurement. If the differences are still greater than ± 4 dB, the site and the surrounding area are suspect. The vertical site attenuation should in general be the most sensitive to site anomalies. If so, use that measurement as the basis for tracking down the problem. Possible problems include inadequate ground plane construction and size, reflecting objects too close by (fences, buildings, light towers, etc.), degraded performance of all-weather enclosures due to inadequate construction and maintenance techniques, and such long-term effects as penetration of residue from airborne conductive contaminants.

E.5 Antenna calibration

The antenna factors of broadband antennas used to make site attenuation measurements should be traceable to a national standard*. Manufacturer's antenna factors may not be sufficiently accurate to achieve good agreement between measured and calculated normalized site attenuations. Antenna factors usually account for losses due to the balun. If a separate balun is used, its effects shall be accounted for. Experience has shown that variations of antenna factors with geometry and polarization are generally negligible for the types of broadband antennas commonly used for EMC measurements below 1 GHz (e.g., biconicals, thick dipoles and log-periodics) as long as the transmit antenna is at least 1 m above the ground plane. If antenna factor variations are suspected because of the use of unusual antennas or measurement geometries, or from effects such as mutual coupling, or transmission line scattering for vertically polarized antennas, especially at the 3-m measurement distance, the antenna factors should first be measured using these geometries.

Normally the site attenuation is measured in a 50 Ω system, i.e. the signal generator and measuring receiver have an impedance of 50 Ω and the radiation impedances of the transmitting and receiving antennas are balanced and matched via a balun.

* A calibration procedure is under consideration.

Manufacturer's antenna factors are normally also specified for an impedance of 50 Ω , i.e. the conversion factor for a without loss matching of the 50 Ω impedance to the radiation impedance of the antenna and, if applicable, the loss of the used balun is also contained in the given antenna factor.

If tuned half-wave dipoles are used, their free-space antenna factors can be calculated, using the following equation:

$$AF = 20 \lg (2\pi/\lambda) + 10 \lg (73/50) \quad (\text{dB}) \quad (\text{E.1})$$

$$= 20 \lg f - 31,9 \quad (\text{dB}) \quad (\text{E.2})$$

where

f is in MHz.

NOTE In practice, the antenna factor will be affected by the height of the dipole antenna above ground because of the mutual impedance of the dipole and its image in the ground.

The average balun loss for a well designed tuned half-wave dipole is approximately 0,5 dB. Hence equation (E.2) becomes

$$AF = 20 \lg f - 31,4 \quad (\text{dB}) \quad (\text{E.3})$$

This balun loss should be measured by connecting transmit and receive dipole back to back before they are installed in their housings. The loss per balun is 1/2 of the total loss measured, assuming both baluns are equal.

It is important to check that these calculated values are representative of the values for the particular tuned dipoles used for the NSA measurements. The simplest check is to measure the VSWR with the antennas assembled and its elements tuned to resonance. The antenna shall be placed at least 4 m above the ground, higher if possible, to minimize antenna to ground coupling, and its elements tuned to resonance using the measurements shown in table E.3. It is sufficient to check the VSWR of the antennas at frequencies in the low end, middle and high end of their frequency ranges.

Below 100 MHz, the function of the baluns may also be checked by removing the elements, placing a 70 Ω resistor across the terminals of the element mounting block, and measuring the VSWR of the terminated balun. The VSWR should be less than 1,5 to 1.

Table E.1 – Normalized site attenuation*
(Recommended geometries for broadband antennas)

Polarization	Horizontal	Horizontal	Horizontal	Horizontal	Vertical	Vertical	Vertical	Vertical
<i>R</i> (m)	3	10	30	30	3	10	30	30
<i>h</i> ₁ (m)	1	1	1	1	1	1	1	1
<i>h</i> ₂ (m)	1 to 4	1 to 4	2 to 6	1 to 4	1 to 4	1 to 4	2 to 6	1 to 4
<i>f</i> _m (MHz)	<i>A</i> _N (dB)							
30	15,8	29,8	44,4	47,8	8,2	16,7	26,1	26,0
35	13,4	27,1	41,7	45,1	6,9	15,4	24,7	24,7
40	11,3	24,9	39,4	42,8	5,8	14,2	23,6	23,5
45	9,4	22,9	37,3	40,8	4,9	13,2	22,5	22,5
50	7,8	21,1	35,5	38,9	4,0	12,3	21,6	21,6
60	5,0	18,0	32,4	35,8	2,6	10,7	20,1	20
70	2,8	15,5	29,7	33,1	1,5	9,4	18,7	18,7
80	0,9	13,3	27,5	30,8	0,6	8,3	17,6	17,5
90	-0,7	11,4	25,5	28,8	-0,1	7,3	16,6	16,5
100	-2,0	9,7	23,7	27	-0,7	6,4	15,7	15,6
120	-4,2	7,0	20,6	23,9	-1,5	4,9	14,1	14,0
140	-6,0	4,8	18,1	21,2	-1,8	3,7	12,8	12,7
160	-7,4	3,1	15,9	19	-1,7	2,6	11,7	11,5
180	-8,6	1,7	14,0	17	-1,3	1,8	10,8	10,5
200	-9,6	0,6	12,4	15,3	-3,6	1,0	9,9	9,6
250	-11,9	-1,6	9,1	11,6	-7,7	-0,5	8,2	7,7
300	-12,8	-3,3	6,7	8,8	-10,5	-1,5	6,8	6,2
400	-14,8	-5,9	3,6	4,6	-14,0	-4,1	5,0	3,9
500	-17,3	-7,9	1,7	1,8	-16,4	-6,7	3,9	2,1
600	-19,1	-9,5	0	0	-16,3	-8,7	2,7	0,8
700	-20,6	-10,8	-1,3	-1,3	-18,4	-10,2	-0,5	-0,3
800	-21,3	-12,0	-2,5	-2,5	-20,0	-11,5	-2,1	-1,1
900	-22,5	-12,8	-3,5	-3,5	-21,3	-12,6	-3,2	-1,7
1 000	-23,5	-13,8	-4,5	-4,4	-22,4	-13,6	-4,2	-3,5

* These data apply to antennas that have at least 25 cm of ground plane clearance when the centre of the antennas is 1 m above the ground plane in vertical polarization.

Table E.2 – Normalized site attenuation

(Recommended geometries for tuned half-wave dipoles, horizontal polarization)

Polarization R (m) h_1 (m) h_2 (m)	Horizontal 3** 2 1 to 4	Horizontal 10 2 1 to 4	Horizontal 30 2 2 to 6
f_m (MHz)	A_N (dB)		
30	11,0	24,1	38,4
35	8,8	21,6	35,8
40	7,0	19,4	33,5
45	5,5	17,5	31,5
50	4,2	15,9	29,7
60	2,2	13,1	26,7
70	0,6	10,9	24,1
80	-0,7	9,2	21,9
90	-1,8	7,8	20,1
100	-2,8	6,7	18,4
120	-4,4	5,0	15,7
140	-5,8	3,5	13,6
160	-6,7	2,3	11,9
180	-7,2	1,2	10,6
200	-8,4	0,3	9,7
250	-10,6	-1,7	7,7
300	-12,3	-3,3	6,1
400	-14,9	-5,8	3,5
500	-16,7	-7,6	1,6
600	-18,3	-9,3	0
700	-19,7	-10,6	-1,3
800	-20,8	-11,8	-2,4
900	-21,8	-12,9	-3,5
1 000	-22,7	-13,8	-4,4

** The mutual impedance correction factors (see table E.4) for horizontally polarized tuned half-wave dipoles spaced 3 m apart should be subtracted from the measured normalized site attenuation data for comparison with the theoretical normalized site attenuation values for an ideal site given in this table.

Table E.3 – Normalized site attenuation

(Recommended geometries for tuned half-wave dipoles – vertical polarization)

f_m MHz	$R = 3 \text{ m}$ $h_1 = 2,75 \text{ m}$		$R = 10 \text{ m}$ $h_1 = 2,75 \text{ m}$		$R = 30 \text{ m}$ $h_1 = 2,75 \text{ m}$	
	h_2 (m)	A_N (dB)	h_2 (m)	A_N (dB)	h_2 (m)	A_N (dB)
30	2,75 to 4	12,4	2,75 to 4	18,8	2,75 to 6	26,3
35	2,39 to 4	11,3	2,39 to 4	17,4	2,39 to 6	24,9
40	2,13 to 4	10,4	2,13 to 4	16,2	2,13 to 6	23,8
45	1,92 to 4	9,5	1,92 to 4	15,1	2 to 6	22,8
50	1,75 to 4	8,4	1,75 to 4	14,2	2 to 6	21,9
60	1,50 to 4	6,3	1,50 to 4	12,6	2 to 6	20,4
70	1,32 to 4	4,4	1,32 to 4	11,3	2 to 6	19,1
80	1,19 to 4	2,8	1,19 to 4	10,2	2 to 6	18,0
90	1,08 to 4	1,5	1,08 to 4	9,2	2 to 6	17,1
100	1 to 4	0,6	1 to 4	8,4	2 to 6	16,3
120	1 to 4	-0,7	1 to 4	7,5	2 to 6	15,0
140	1 to 4	-1,5	1 to 4	5,5	2 to 6	14,1
160	1 to 4	-3,1	1 to 4	3,9	2 to 6	13,3
180	1 to 4	-4,5	1 to 4	2,7	2 to 6	12,8
200	1 to 4	-5,4	1 to 4	1,6	2 to 6	12,5
250	1 to 4	-7,0	1 to 4	-0,6	2 to 6	8,6
300	1 to 4	-8,9	1 to 4	-2,3	2 to 6	6,5
400	1 to 4	-11,4	1 to 4	-4,9	2 to 6	3,8
500	1 to 4	-13,4	1 to 4	-6,9	2 to 6	1,8
600	1 to 4	-14,9	1 to 4	-8,4	2 to 6	0,2
700	1 to 4	-16,3	1 to 4	-9,7	2 to 6	-1,0
800	1 to 4	-17,4	1 to 4	-10,9	2 to 6	-2,4
900	1 to 4	-18,5	1 to 4	-12,0	2 to 6	-3,3
1 000	1 to 4	-19,4	1 to 4	-13,0	2 to 6	-4,2

Table E.4 – Mutual coupling correction factors for geometry using resonant tunable dipoles spaced 3 m apart

ΔAF_{TOT} – Total correction factor in decibels		
f_m MHz	Horizontal polarization $R = 3$ m $h_1 = 2$ m $h_2 = 1$ m to 4 m	Vertical polarization $R = 3$ m $h_1 = 2,75$ m $h_2 =$ (see table E.3.)
30	3,1	2,9
35	4,0	2,6
40	4,1	2,1
45	3,3	1,6
50	2,8	1,5
60	1,0	2,0
70	-0,4	1,5
80	-1,0	0,9
90	-1,0	0,7
100	-1,2	0,1
120	-0,4	-0,2
125	-0,2	-0,2
140	-0,1	0,2
150	-0,9	0,4
160	-1,5	0,5
175	-1,8	-0,2
180	-1,0	-0,4

NOTE 1 The values for the resonant dipoles were calculated using the method of moments and the numerical electromagnetic code (NEC) or the MININEC computer system.

G.J. Burke and A.J. Poggio, *Numerical Electromagnetic Code – Method of Moments*, Lawrence Livermore Laboratory, California, January, 1981.

J.W. Rockway, J.C. Logan, D.W.S. Tam, S.T. Li, *The MININEC System: Microcomputer Analysis of Wire Antennas*, Artech House, Boston, 1988.

Berry, J.; Pate, B.; Knight: "Variations in Mutual Coupling Correction Factors for Resonant Dipoles Used In Site Attenuation Measurements", Proc IEEE Sym on EMC, Washington, DC, 1990.

NOTE 2 Theoretical free-space antenna factors for ideal resonant dipoles with a 0,5 dB balun loss (for each antenna) are assumed.

NOTE 3 These correction factors do not completely describe antenna factors measured above a ground plane, e.g. at heights of 3 or 4 m, since these antenna factors differ from free-space antenna factors at the lower frequencies. However, within the error bounds described in table M, the values are adequate to indicate site anomalies.

NOTE 4 The user is cautioned that some half-wavelength dipoles or antennas with unusual baluns may exhibit different characteristics than the antenna in E.5.

NOTE 5 Mutual coupling correction factors for 10 m and 30 m are under consideration. As an interim procedure, site adequacy can be assessed by considering these correction factors to be equal to zero.

Annex F (informative)

Basis for 4 dB site acceptability criterion (clause 5)

F.1 General

This annex shows the basis for the acceptability criterion of ± 4 dB for the normalized site attenuation measurements required in 5.6.

F.2 Error analysis

The error analysis in table F.1 applies to the normalized site attenuation measurement methods given in 5.6. The total estimated errors are the basis for the ± 4 dB site acceptability criterion consisting of approximately 3 dB measurement uncertainty and an additional allowable 1 dB for site imperfections.

The error budget in table F.1 does not include uncertainties in the amplitude stability of the signal generator, tracking generator, or any amplifiers that may be used, nor does it include the potential errors in measurement technique. The output level of most signal and tracking generators will drift with time and temperature, and the gain of many amplifiers will drift as temperature changes. It is imperative that these sources of error be held to an insignificant amount or corrected in making the measurements, otherwise the site may fail to meet the acceptability criterion due to instrumentation problems alone.

Table F.1 – Error budget

Error item	Measurement method	
	Discrete method dB	Sweep frequency method dB
Antenna factor (Tx)*	± 1	± 1
Antenna factor (Rx)*	± 1	± 1
Voltmeter	0	$\pm 1,6^{**}$
Attenuator	± 1	0
Site imperfections	± 1	± 1
Totals	± 4	$\pm 4,6$

* At frequencies above 800 MHz, AF errors may approach $\pm 1,5$ dB.
** From the operating instructions.

From the operating instructions for some automatic spectrum analyzers, for example, if everything is done to remove or compensate every potential error as much as possible the remaining amplitude errors are:

- 1) $\pm 0,2$ dB calibrator uncertainty,
- 2) $\pm 1,0$ dB frequency response flatness,
- 3) $\pm 1,0$ dB input attenuator switching,
- 4) $\pm 0,4$ dB RF and IF gain uncertainty.

This gives a total potential error of $\pm 2,6$ dB. This does not include $\pm 0,05$ dB/K temperature drift. In practice, when performing substitution type measurements the errors associated with the frequency response flatness and input attenuator switching are usually 1 dB less, so that the total error band for the spectrum analyzer as a two-terminal voltmeter is $\pm 1,6$ dB or less, which is used in table F.1.

Many attenuators have far poorer absolute accuracy, but some are better. The total error budget could thus be increased or decreased in the discrete measurements. If an external attenuator is used with the automatic spectrum analyzer in the swept frequency measurements this error budget is also increased.

These error budgets do not contain errors from time and temperature induced drifts of the gains, output levels, or amplitude responses of the test equipment. Such errors may exist and steps shall be taken to avoid them by making the measurements as rapidly as possible.

In practice, the errors accounted for above seldom are all in the same direction. Meeting the ± 4 dB criterion for a well constructed and located site may actually allow more than ± 1 dB site anomaly variation from ideal.
